

SERVICE MANUAL



Model:

PDP4210EA

Safety Precaution
Technical Specifications
Block Diagram
Circuit Diagram
Basic Operations & Circuit Description
Main IC Specifications
Product Specification of PDP Module
Trouble Shooting Manual of PDP Module
Spare Part List
Exploded View
If you forget your V-Chip Password
Software Upgrade

This manual is the latest at the time of printing, and does not include the modification which may be made after the printing, by the constant improvement of product.

Safety Precaution

 <div style="border: 1px solid black; padding: 5px; text-align: center;">CAUTION RISK OF ELECTRIC SHOCK DO NOT OPEN</div> 	<p>The lightning flash with arrowhead symbol, within an equilateral triangle, is intended to alert the user to the presence of uninsulated "dangerous voltage" within the product's enclosure that may be of sufficient magnitude to constitute a risk of electric shock to persons.</p> <p>The exclamation point within an equilateral triangle is intended to alert the user to the presence of important operating and maintenance (servicing) instructions in the literature accompanying the appliance.</p>
---	--

CAUTION: TO REDUCE THE RISK OF ELECTRIC SHOCK, DO NOT REMOVE COVER (OR BACK). NO USER-SERVICEABLE PARTS INSIDE. REFER SERVICING TO QUALIFIED SERVICE PERSONNEL ONLY.

PRECAUTIONS DURING SERVICING

- In addition to safety, other parts and assemblies are specified for conformance with such regulations as those applying to spurious radiation. These must also be replaced only with specified replacements.
Examples: RF converters, tuner units, antenna selection switches, RF cables, noise-blocking capacitors, noise-blocking filters, etc.
- Use specified internal Wiring. Note especially:
 - Wires covered with PVC tubing
 - Double insulated wires
 - High voltage leads
- Use specified insulating materials for hazardous live parts. Note especially:
 - Insulating Tape
 - PVC tubing
 - Spacers (insulating barriers)
 - Insulating sheets for transistors
 - Plastic screws for fixing micro switches
- When replacing AC primary side components (transformers, power cords, noise blocking capacitors, etc.), wrap ends of wires securely about the terminals before soldering.

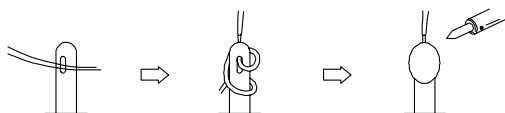

- Make sure that wires do not contact heat generating parts (heat sinks, oxide metal film resistors, fusible resistors, etc.)
- Check if replaced wires do not contact sharply edged or pointed parts.
- Make sure that foreign objects (screws, solder droplets, etc.) do not remain inside the set.

MAKE YOUR CONTRIBUTION TO PROTECT THE ENVIRONMENT

Used batteries with the ISO symbol



for recycling as well as small accumulators (rechargeable batteries), mini-batteries (cells) and starter batteries should not be thrown into the garbage can.

Please leave them at an appropriate depot.

WARNING:

Before servicing this TV receiver, read the **SAFETY INSTRUCTION** and **PRODUCT SAFETY NOTICE**.

SAFETY INSTRUCTION

The service should not be attempted by anyone unfamiliar with the necessary instructions on this apparatus. The following are the necessary instructions to be observed before servicing.

- An isolation transformer should be connected in the power line between the receiver and the AC line when a service is performed on the primary of the converter transformer of the set.
- Comply with all caution and safety related provided on the back of the cabinet, inside the cabinet, on the chassis or picture tube.
- To avoid a shock hazard, always discharge the picture tube's anode to the chassis ground before removing the anode cap.
- Completely discharge the high potential voltage of the picture tube before handling. The picture tube is a vacuum and if broken, the glass will explode.

5. When replacing a MAIN PCB in the cabinet, always be certain that all protective are installed properly such as control knobs, adjustment covers or shields, barriers, isolation resistor networks etc.
6. When servicing is required, observe the original lead dressing. Extra precaution should be given to assure correct lead dressing in the high voltage area.
7. Keep wires away from high voltage or high temperature components.
8. Before returning the set to the customer, always perform an AC leakage current check on the exposed metallic parts of the cabinet, such as antennas, terminals, screwheads, metal overlay, control shafts, etc., to be sure the set is safe to operate without danger of electrical shock. Plug the AC line cord directly to the AC outlet (do not use a line isolation transformer during this check). Use an AC voltmeter having 5K ohms volt sensitivity or more in the following manner. Connect a 1.5K ohm 10 watt resistor paralleled by a 0.15 μ F AC type capacitor, between a good earth ground (water pipe, conductor etc.,) and the exposed metallic parts, one at a time. Measure the AC voltage across the combination of the 1.5K ohm resistor and 0.15 μ F capacitor. Reverse the AC plug at the AC outlet and repeat the AC voltage measurements for each exposed metallic part.

The measured voltage must not exceed 0.3V RMS.

This corresponds to 0.5mA AC. Any value exceeding this limit constitutes a potential shock hazard and must be corrected immediately.

The resistance measurement should be done between accessible exposed metal parts and power cord plug prongs with the power switch "ON". The resistance should be more than 6M ohms.

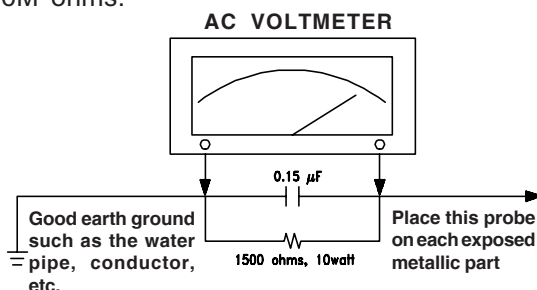

AC Leakage Current Check

PRODUCT SAFETY NOTICE

Many electrical and mechanical parts in this apparatus have special safety-related characteristics.

These characteristics are often passed unnoticed by visual inspection and the protection afforded by them cannot necessarily be obtained by using replacement components rated for a higher voltage, wattage, etc.

The replacement parts which have these special safety characteristics are identified by \triangle marks on the schematic diagram and on the parts list.

Before replacing any of these components, read the parts list in this manual carefully. The use of substitute replacement parts which do not have the same safety characteristics as specified in the parts list may create shock, fire, or other hazards.

9. Must be sure that the ground wire of the AC inlet is connected with the ground of the apparatus properly.

Technical Specifications		MODEL : <u>PDP4210EA</u> 42" Plasma Display		
DATE FIRST ISSUED	ISSUE 1	RAISED BY	CHECKED BY	NUMBER OF PAGES 10

REVISIONS			
ISSUED	DATE	DESCRIPTION	RAISED BY :

SPECIFICATION AGREED :	SIGNATURE	DATE
R & D DEPARTMENT
COMMERCIAL DEPARTMENT
PRODUCTION DEPARTMENT
Q/A DEPARTMENT
CUSTOMER

SPECIFICATION APPROVED :	SIGNATURE :	DATE :

NOTE : Only documents stamped "Controlled Document" to be used for manufacture of production parts.

1. Standard Test Conditions

All tests shall be performed under the following conditions, unless otherwise specified.

- 1.1 Ambient light : 150ux (When measuring I_B , the ambient luminance $\cong 0.1\text{Cd/m}^2$)
- 1.2 Viewing distance : 50cm in front of PDP
- 1.3 Warm up time : 30 minutes
- 1.4 PDP Panel facing : no restricted
- 1.5 Measuring Equipment : PC, Chroma 2225 signal generator (with Chroma digital additional card) or equivalent, Minolta CA100 photometer
- 1.6 Magnetic field : no restricted
- 1.7 Control settings : Brightness, Contrast, Tint, Color set at Center(50)
- 1.8 Power input : 110~120Vac,60Hz
- 1.9 Ambient temperature : $20^{\circ}\text{C} \pm 5^{\circ}\text{C}$ ($68^{\circ}\text{F} \pm 9^{\circ}\text{F}$)
- 1.10 Display mode : 31.5KHz/60Hz (Resolution 852 x 480)
- 1.11 Other conditions :
 - 1.11.1 With image sticking protection of PDP module, the luminance will descend by time on a same still screen and rapidly go down in 5 minutes. When measuring the color tracking and luminance of a same still screen, be sure to accomplish the measurement in one minute to ensure its accuracy.
 - 1.11.2 Due to the structure of PDP, the extra-high-bright same screen should not hold over 5 minutes for fear of branding on the panel.

ELECTRICAL CHARACTERISTICS

2. Power Input

- 2.1 Voltage : 110 ~120VAC
- 2.2 Input Current : 3.5A
- 2.3 Maximum Inrush Current : <30 A (FOR AC110V ONLY)
Test condition : Measured when switched off for at least 20 mins
- 2.4 Frequency : 60Hz(±3Hz)
- 2.5 Power Consumption : ≤ 330W
Test condition : full white display with maximum brightness and contrast
- 2.6 Power Factor : Meets IEC1000-3-2
- 2.7 Withstanding voltage : 1.5kVac or 2.2kVdc for 1 sec

3. Display

- 3.1 Screen Size : 42" Plasma display
- 3.2 Aspect Ratio : 16:9
- 3.3 Pixel Resolution : 852x480
- 3.4 Peak Brightness : 1000 cd/m² (Panel module without filter)
- 3.5 Contrast Ratio (Dark room) : 3000:1 (Panel module without filter)
- 3.6 Viewing Angle : Over 160°
- 3.7 OSD language : English, Spanish, French

4. Signal

- 4.1 AV & Graphic input
 - 4.1.1 TV standard : NTSC/ATSC
 - 4.1.2 TV Tuning system : 181CH (for NTSC), 2~69CH (for ATSC)
 - 4.1.3 CATV : 125CH (for NTSC)
 - 4.1.4 Composite signal : AV
 - 4.1.5 Y,C Signal : S-Video
 - 4.1.6 Component signal : Y, Pb/Cb, Pr/Cr, HDTV compatible
 - 4.1.7 Graphic I/P : Analog: D-sub 15pin detachable cable
Digital: DVI
 - 4.1.8 PnP compatibility : DDC 1.0
 - 4.1.9 I/P frequency : f_H: 31.5kHz to 60kHz/f_V: 56.25Hz to 75Hz (640x480 recommended)

6.11 Color temperature : Contrast at center (50); Brightness center (50);
Colortemperature set at Natural
x=0.285±0.02
y=0.293±0.02

6.12 Cell Defect Specifications
Subject to Panel supplier specification as appends.

7. Front Panel Control Button

- 7.1 CH Up / Down Button : Push the key to changing the channel up or down.
When selecting the item on OSD menu.
- Volume Up/ Down Button : Push the key to increase the volume up or down.
When selecting the adjusting item on OSD menu
increase or decrease the data-bar.
- Menu Button : Enter to the OSD menu.
- Input Select Button : Push the key to select the input signals source.
- 7.2 Stand by Button : Switch on main power, or switch off to enter power
Saving modes.
- 7.3 Main Power Switch : Turn on or off the unit.

8. OSD Function

Full on screen display

9. Agency Approvals

Safety	UL60950
Emissions	FCC class B

10. Reliability

11.1 MTBF : 20,000 hours(Use moving picture signal at 25°C ambient)

11. Accessories : User manual x1, Remote control x1, Stand x1, Power cord x1, Battery x 2.

13. Support the Signal Mode

A. VGA and DVI mode

NO.	Resolution	Horizontal Frequency (KHz)	Vertical Frequency (Hz)	Dot Clock Frequency (MHz)
1	640 x 400	31.47	70.08	25.17
2	640 x 480	31.50	60.00	25.18
3	640 x 480	37.50	75.00	31.50
4	640 x 480	37.86	72.81	31.50
5	720 x 400	31.47	70.08	28.32
6	800 x 600	35.16	56.25	36.00
7	800 x 600	37.90	60.32	40.00
8	800 x 600	46.90	75.00	49.50
9	800 x 600	48.08	72.19	50.00
10	832 x 624	49.00	75.00	57.27
11	1024 x 768	48.40	60.00	65.00
12	1024 x 768	56.50	70.00	75.00
13	1024 x 768	60.00	75.00	78.75
14	1152 x 864	63.86	70.02	94.51
15	1152 x 864	67.52	75.02	108.03
16	1280 x 720	45.00	60.00	74.25
17	1280 x 960	60.02	60.02	108.04
18	1280 x 1024	64.00	60.01	108.00

B. HDTV Mode (YPbPr)

NO.	Resolution	Horizontal Frequency (KHz)	Vertical Frequency (Hz)	Dot Clock Frequency (MHz)
1	480i	15.734	59.94	13.50
2	480p(720x480)	31.468	59.94	27.00
3	576p(720x576)	31.25	50.00	27.00
4	720p(1280x720)	37.50	50.00	74.25
5	720p(1280x720)	45.00	60.00	74.25
6	1080i(1920x1080)	33.75	60.00	74.25

- When the signal received by the Display exceeds the allowed range, a warning message "Main Not Support!" shall appear on the screen.
- You can confirm the input signal format from the on-screen.
- DVI could not support some PC Graphic cards.

Remote Control

- 1 **Standby** (⏻): Press to turn on and off.
- 2 **Mute** (🔇): Press to mute the sound. Press again to restore the sound.
- 3 **0~9 Number Buttons**: Press 0~9 to select a channel, and used to input the password; the channel changes after 2 seconds.
- 4 **EPG**: Press to display EPG mode. Press it again to exit EPG mode.
- 5 **Input**: Press to select the signal source, such as TV, AV, S-Video, Component 1, Component 2, VGA, DVI or DTV.
- 6 **DTV**: Press to choose DTV directly.
- 7 **Dot**: Press number buttons with it to select the channels directly in DTV.
- 8 **VOL +/-**: Press to adjust the volume.
- 9 **CH +/-**: Press to select the channel forward or backward.
- 10 **MTS**: Press repeatedly to cycle through the Multi-channel TV sound (MTS) options: Mono, Stereo and SAP (Second Audio Program).
- 11 **◀, ▶, ▲, ▼, Enter**: Press **◀, ▶, ▲, ▼** to move the on-screen cursor. To select an item, press **Enter** to confirm. And it can also press **▲** or **▼** to select channels, press **◀** or **▶** to adjust the volume.
- 12 **Exit**: Press this button to exit.
- 13 **Menu**: Press to enter into the on-screen setup menu, press again to exit.
- 14 **V-Chip**: Press to select the child protect mode.
- 15 **CCD**: Press to select the Closed Caption mode.
- 16 **Freeze**: Press to freeze the picture, press again to restore the picture.
- 17 **Display**: Press to display the channel information and it disappear after 3 seconds.
- 18 **Favorite**: Press repeatedly to cycle through the favorite channel list.
- 19 **Add/Erase**: Press to add or delete favorite or dislike channels.
- 20 **S.Mode**: Press repeatedly to cycle through the sound mode: Normal, News, Cinema, Flat and User.
- 21 **PIC Size**: Press repeatedly to cycle through the picture size that best corresponds your viewing requirements: Normal, Full, Wide1, Wide2, Wide3, 4:3, No Scale and Panoramic.

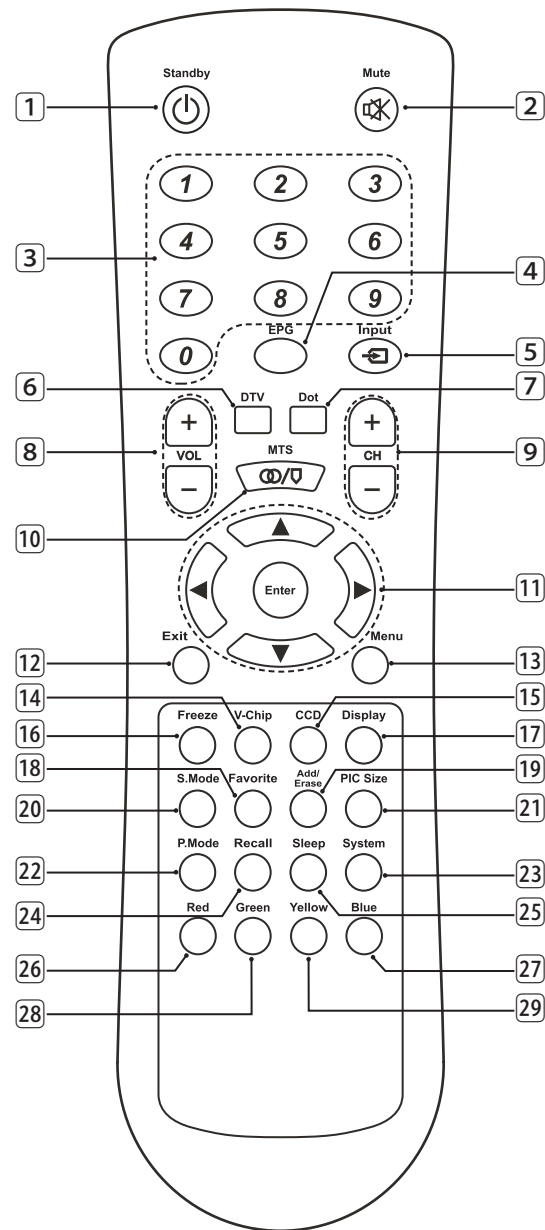

(Continued on next page)

- 22 **P.Mode:** Press repeatedly to cycle through the picture mode: Normal, Vivid, Hi-Bright, User and Dark.
- 23 **System:** Press repeatedly to cycle through the system options: AUTO, and NTSC3.58.
- 24 **Recall:** Press to return to previous channel.
- 25 **Sleep:** Press repeatedly until it displays the time in minutes (5 Min, 10 Min, 15 Min, 30 Min, 60 Min, 90 Min, 120 Min and, OFF) that you want the TV to remain on before shutting off. To cancel sleep time, press SLEEP repeatedly until sleep OFF appears.
- 26 **Red:** Press this button to access the red item or page.
- 27 **Blue:** Press this button to access the blue item or page.
- 28 **Green:** Press this button to access the green item or page.
- 29 **Yellow:** Press this button to access the yellow item or page.

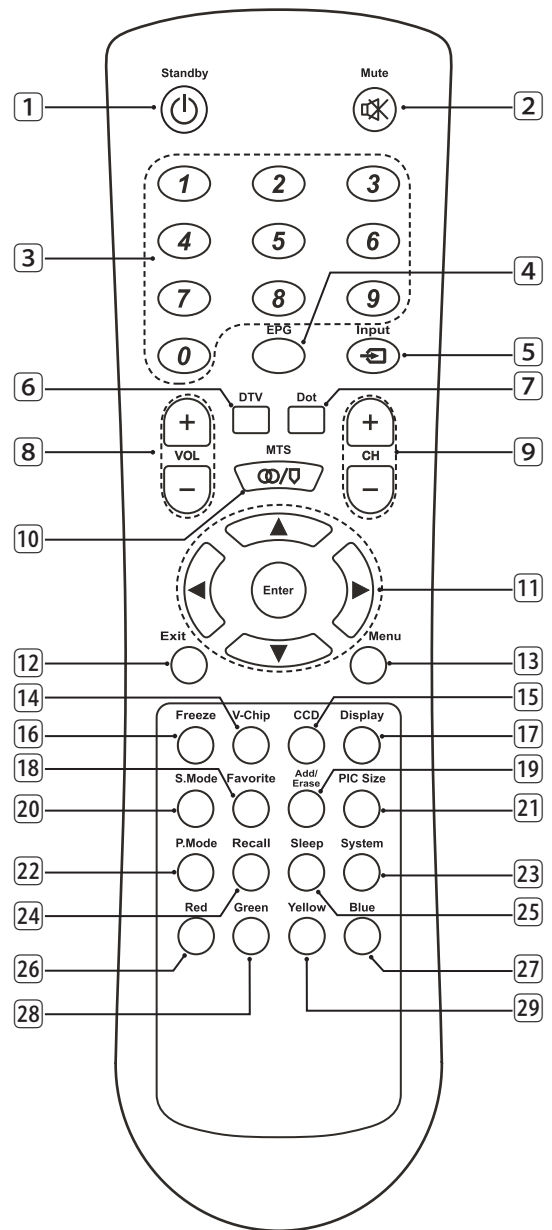

*Note: Press **CH +/-** on the remote control can turn on TV set from standby mode.*

Insertion of Batteries:

- Turn the remote control upside down, press and slide off the battery cover.
- Insert two 1.5V (AAA) batteries into the compartment, take care to observe the ⊕ and ⊖ markings indicated inside.
- Replace the cover and slide in reverse until the lock snaps.

PHYSICAL CHARACTERISTICS**14. Power Cord**

Length : 1.8m nominal
Type : optional

15. Cabinet

15.1 Color : "Black" colour as defined by colour plaque reference number

15.2 Weight

Net weight : 36.2 kg(with stand) /34.0kg(without stand)
Gross weight : 41.0 kg

15.3 Dimensions(with stand)

Width : 1040 mm
Height : 690 mm
Depth : 290 mm

Block Diagram

Product Specification of PDP Module

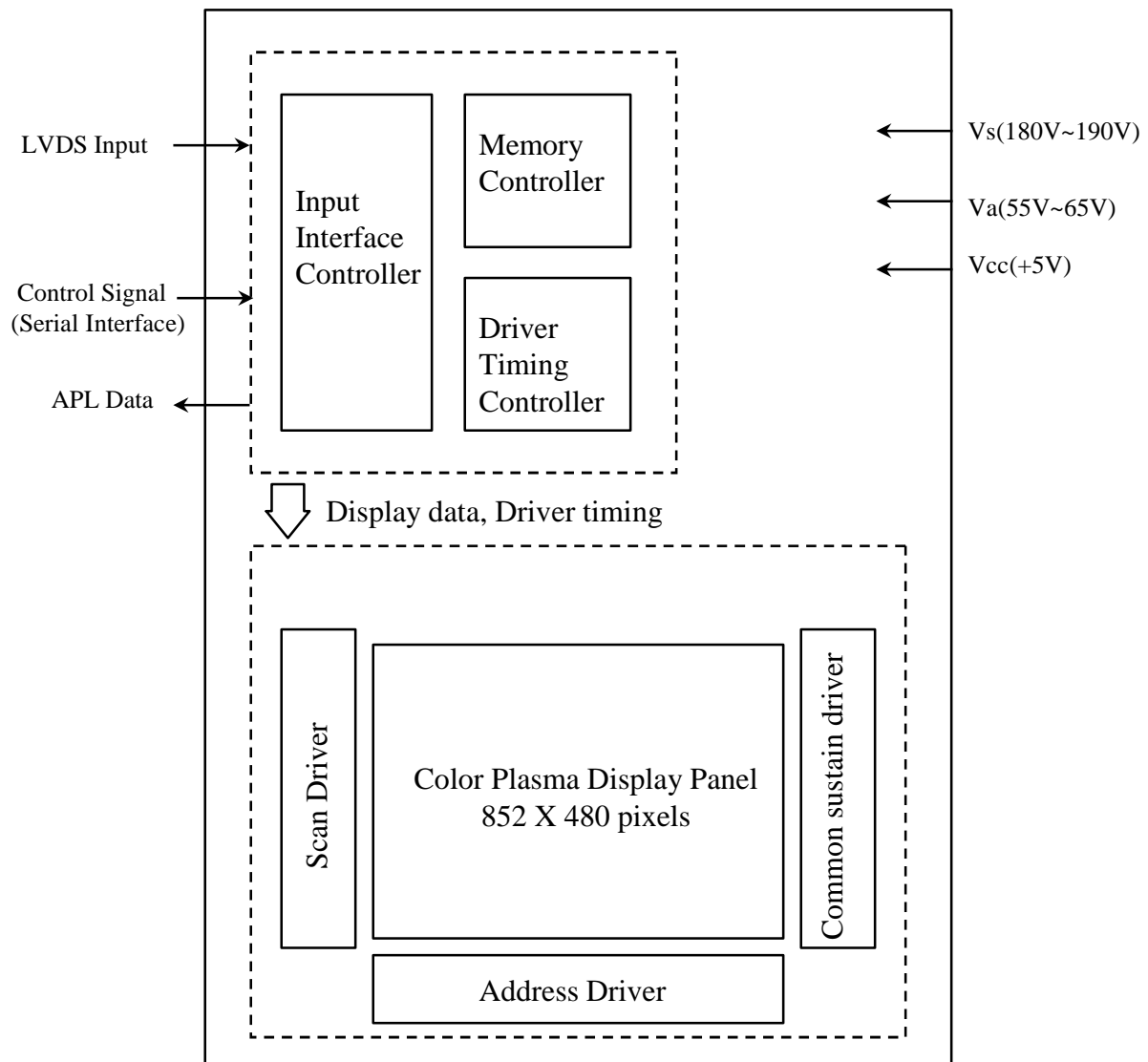

Applied Voltage level is specified at the time when Full-White pattern is displayed on the panel.

Block Diagram

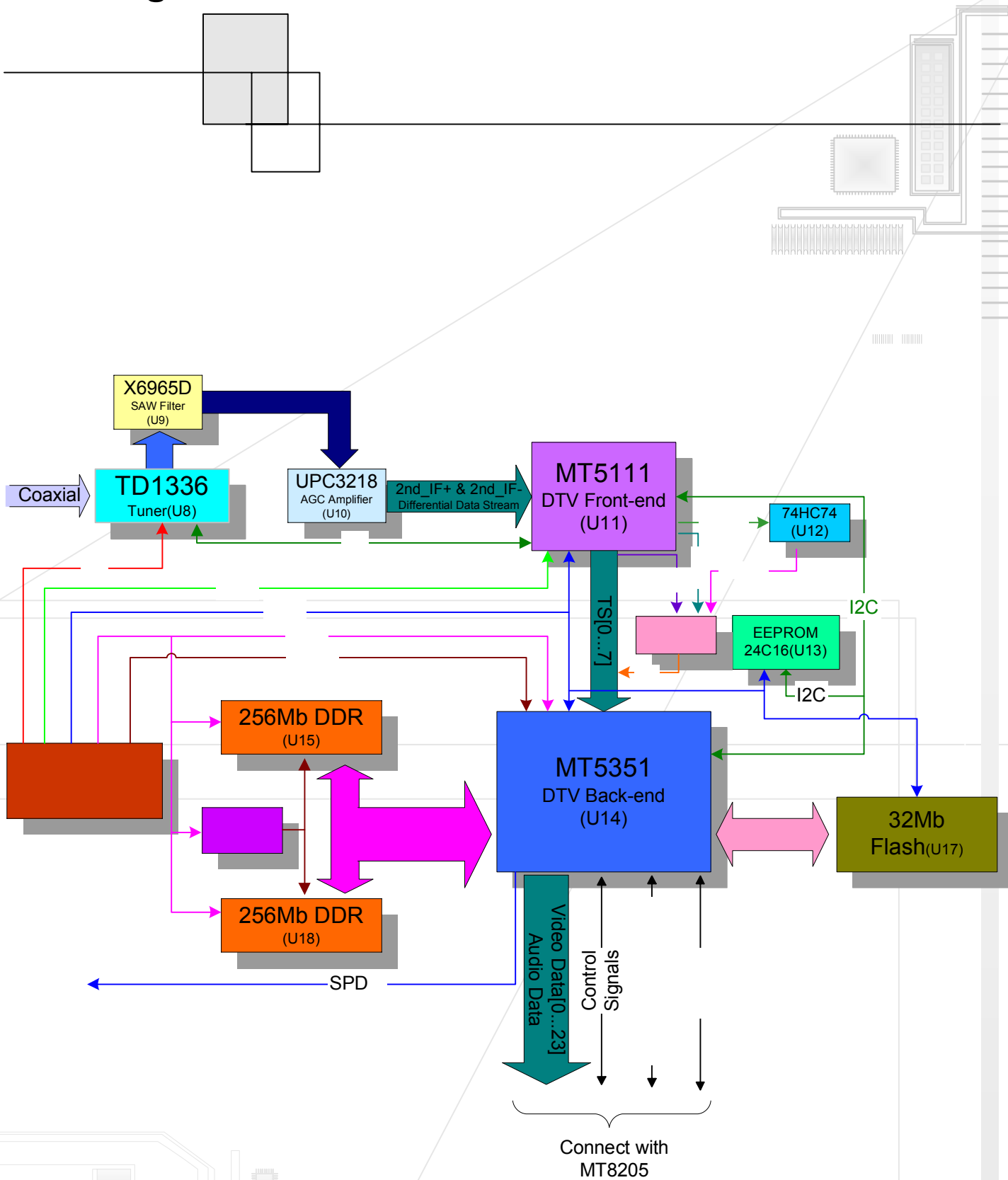

Block Diagram

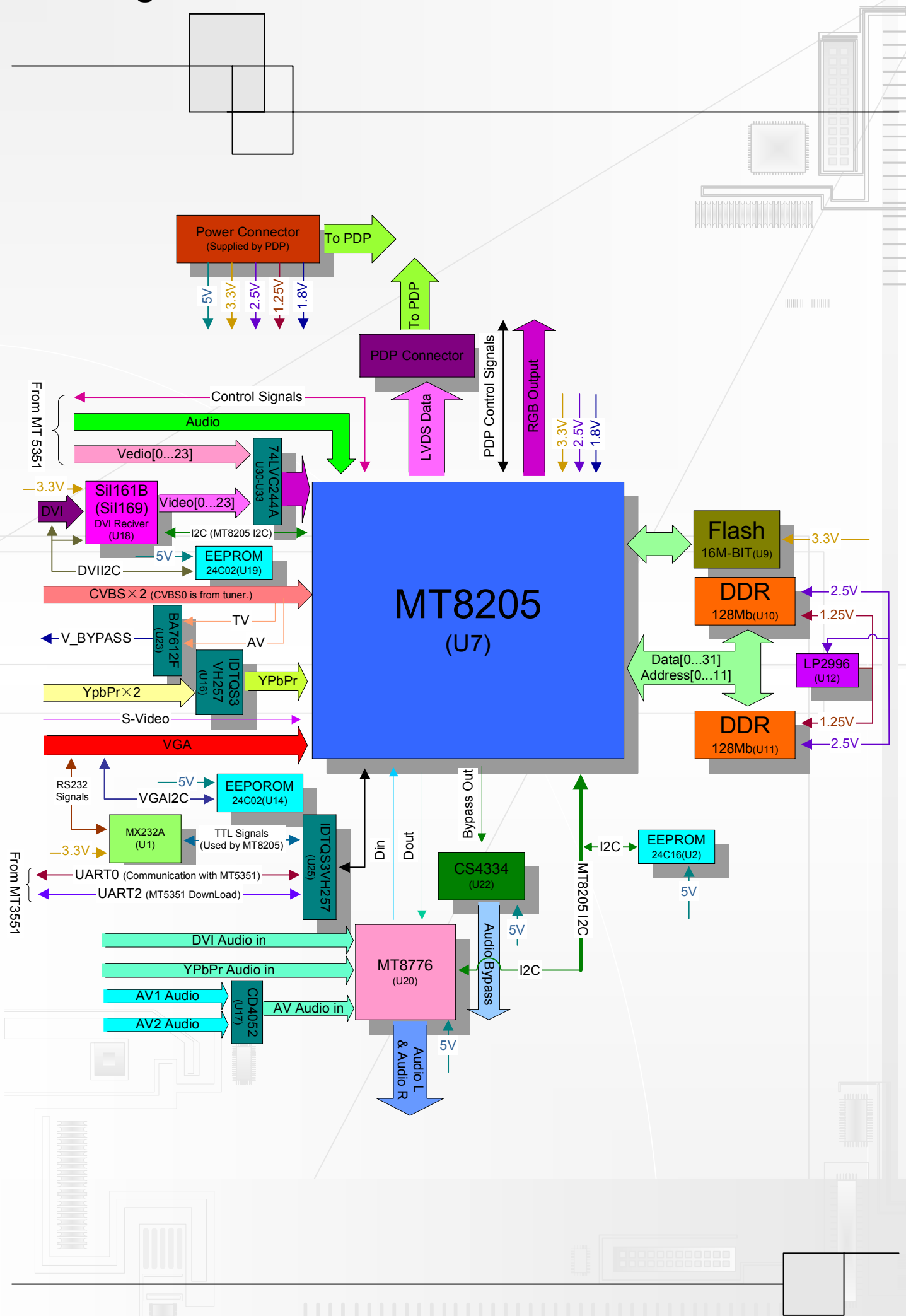

Circuit Diagram

- **Power supply board of PDP Module, DGP-420WXGA**
- **Power supply board of PDP Module, USP490M-42LP**
- **Main (Video) board**
- **Audio/Tuner board**
- **ATSC board**
- **Keypad board**
- **Remote control receiver board**
- **External L/R Speakers board**
- **Remote control board**

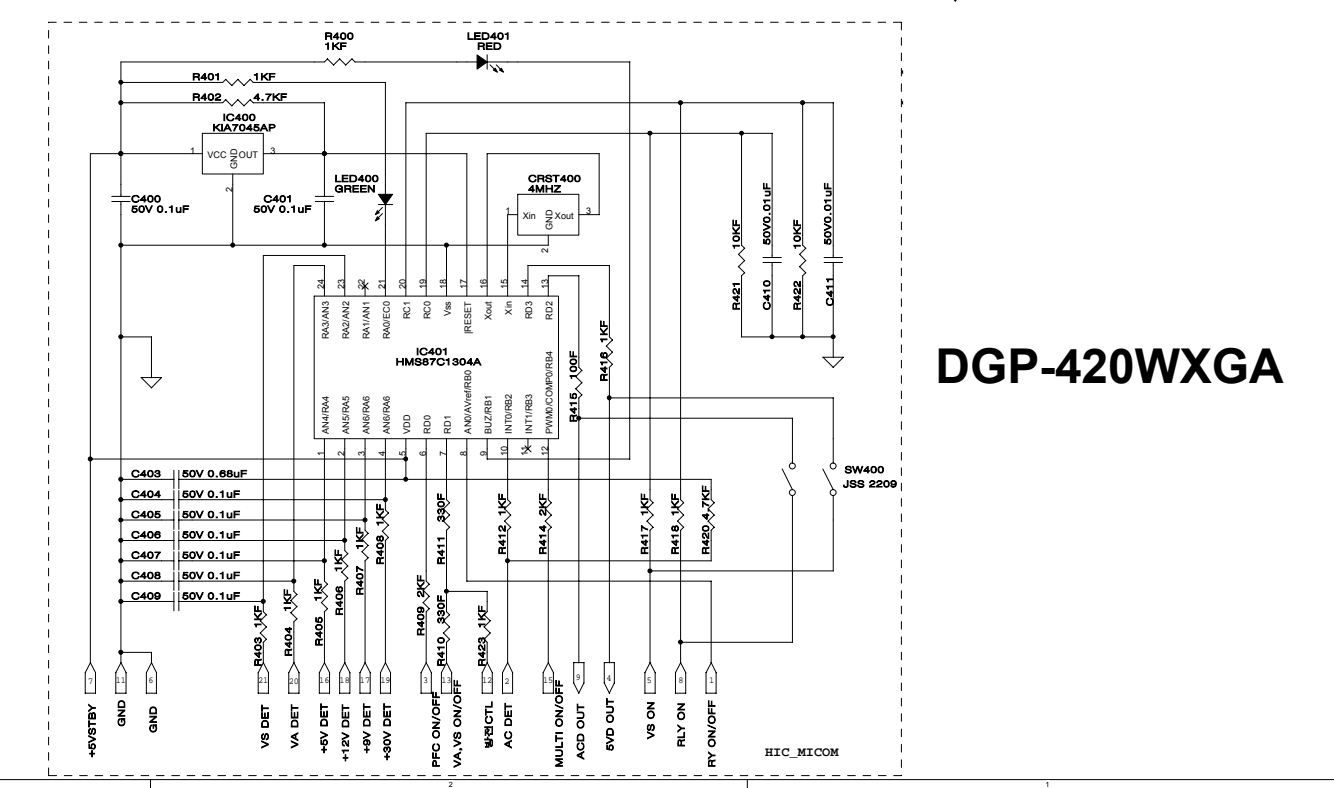
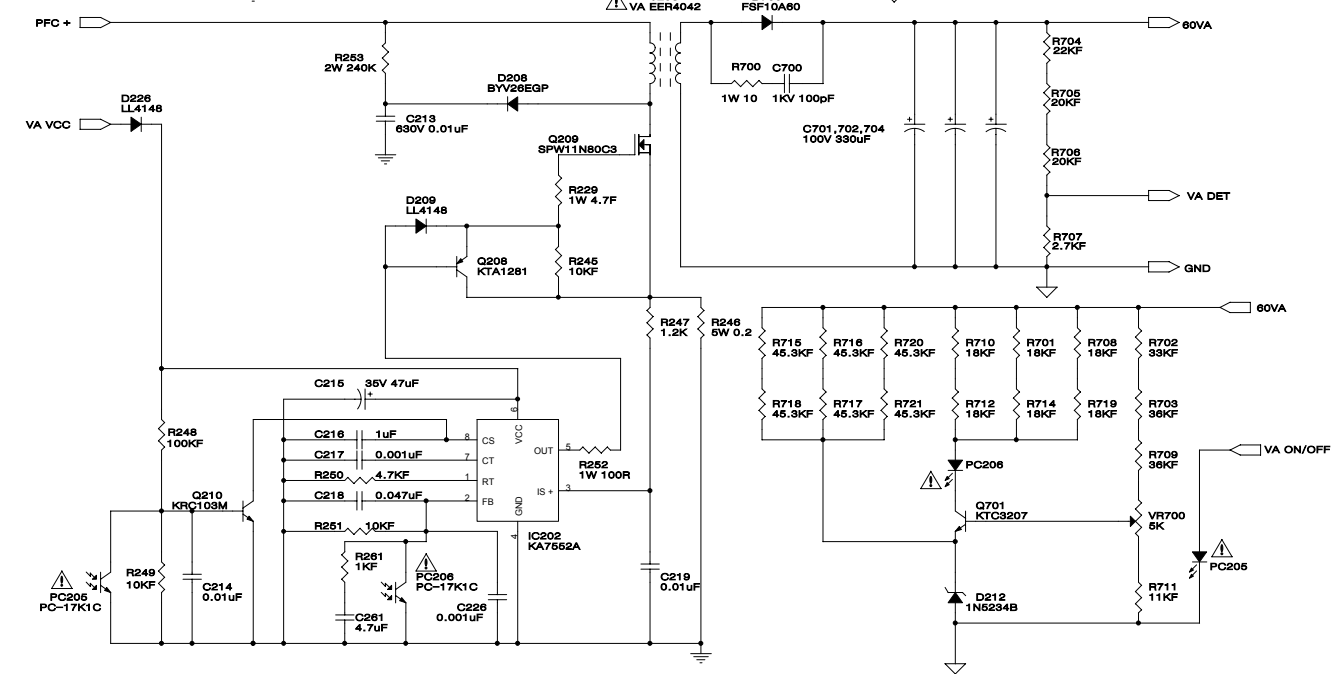
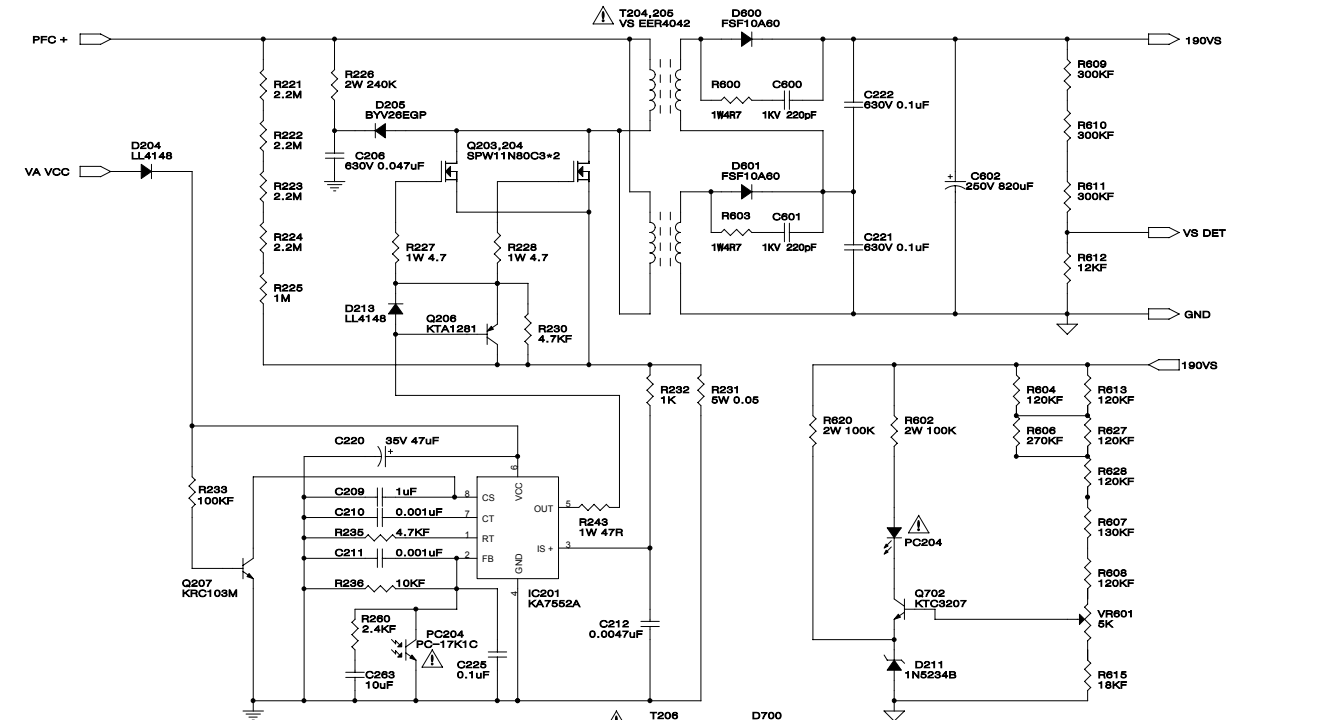
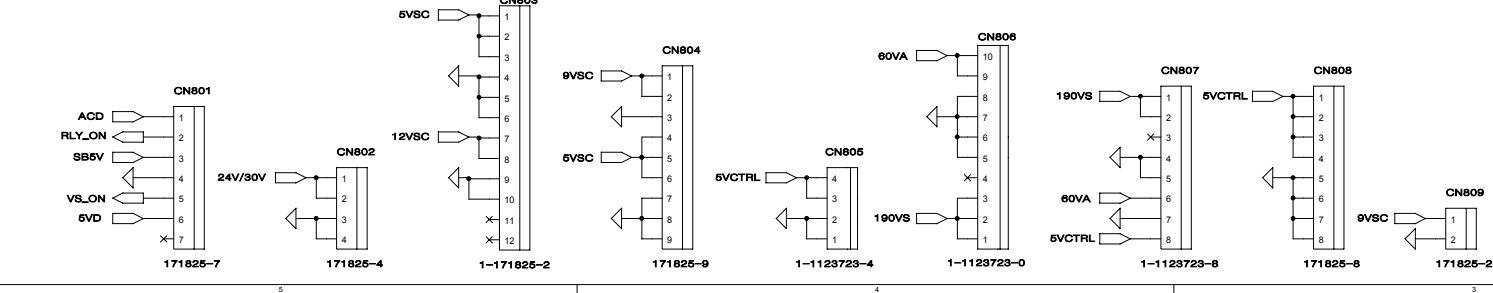
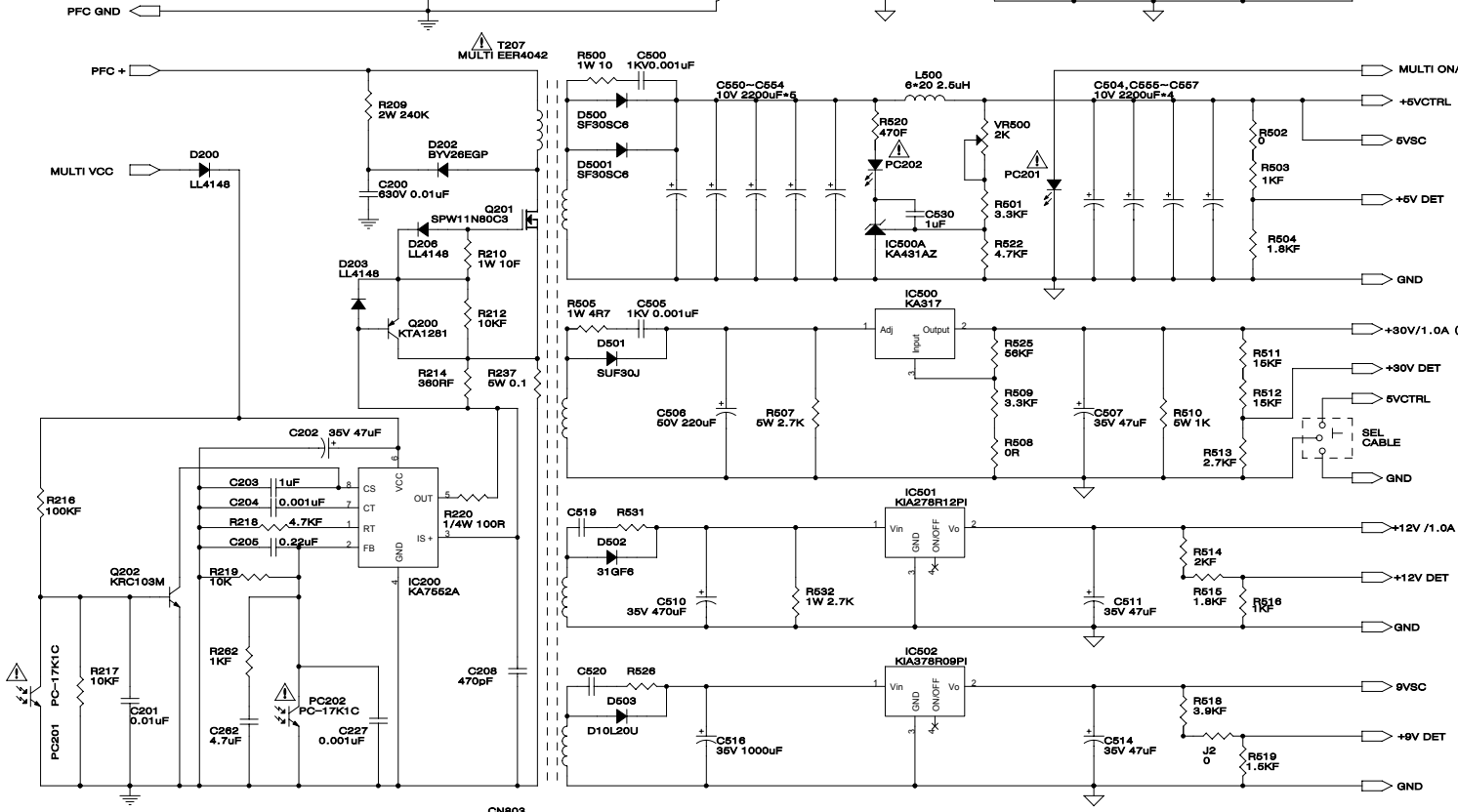
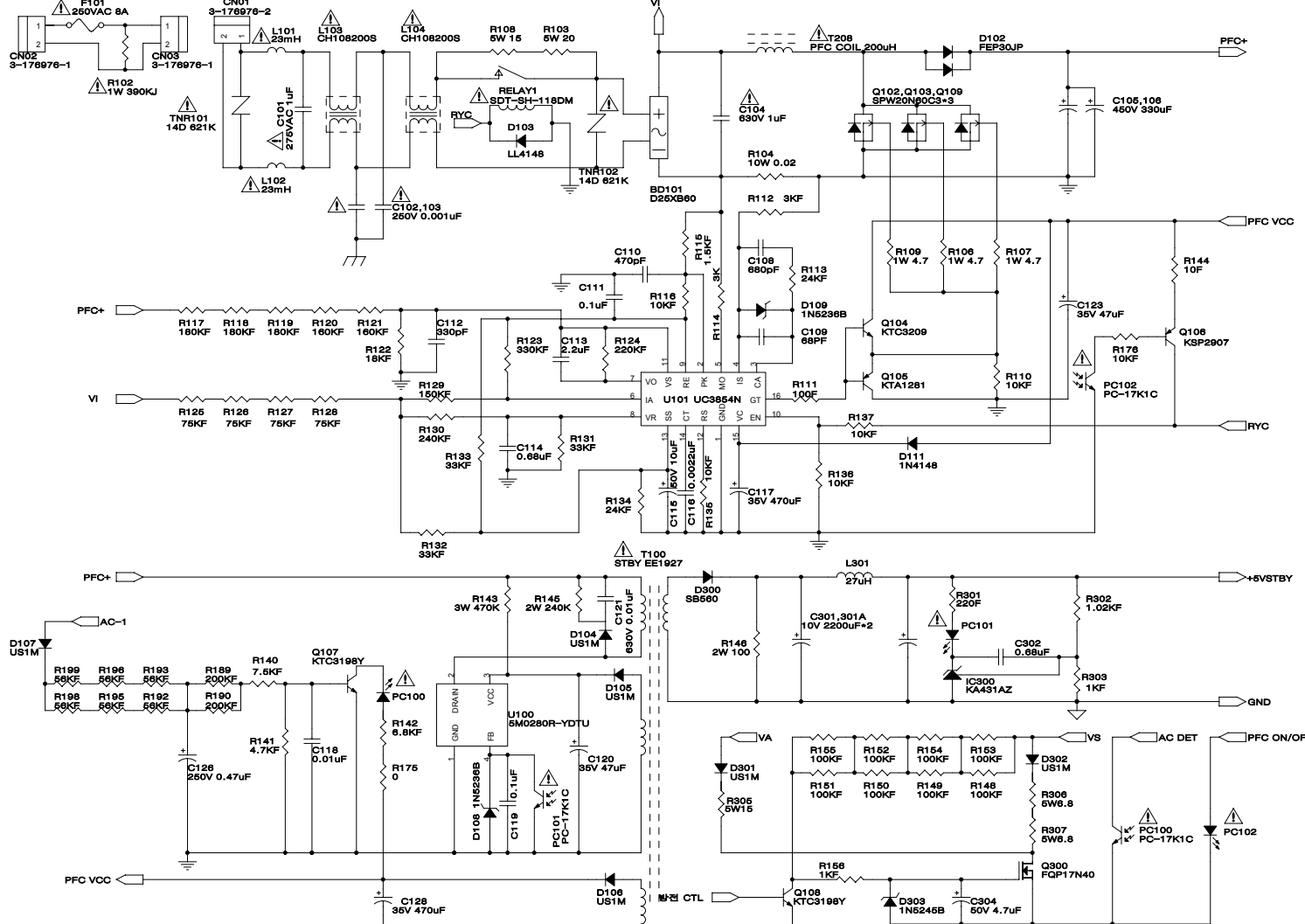

DGP-420WXGA

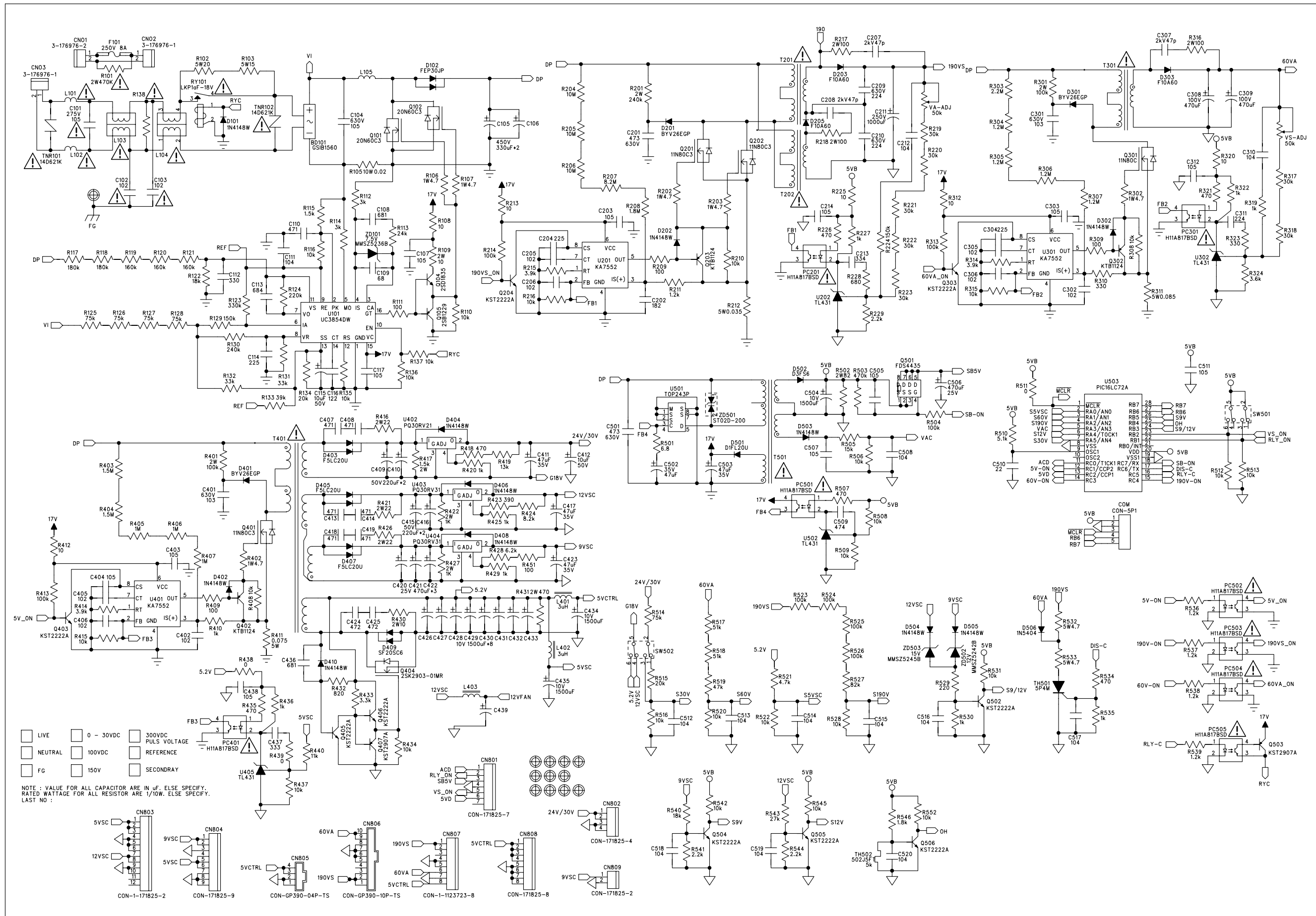

MT8205E (PBGA388) LCDTV BOARD 4 LAYERS

1. INDEX
2. LDO
3. MT8205E PBGA388
4. MT8205 ANALOG DECOUPLING
5. DDR MEMORY & FLASH
6. VGA IN & PC AUDIO IN
7. VIDEO IN & TUNER IO
8. AUDIO/VIDEO IN CIRCUIT
9. DVI INPUT
10. LVDS/CRT/TTL OUT
11. BACK LIGHT / KEYPAD
12. WM8776 & A/V BYPASS
13. ATSC INTERFACE
14. PDP INTERFACE

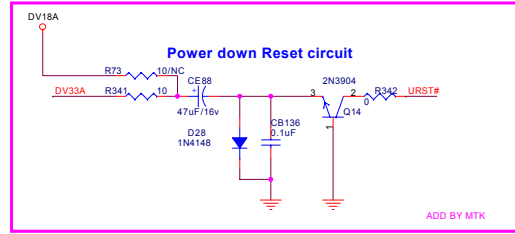

RSRXD	>>>RSRXD	6
RSTXD	>>>RSTXD	8
PCRXD	>>>PCRXD	13
PCTXD	>>>PCTXD	13
RXD	>>>RXD	3,13
RXD	>>>RXD	3,13
SCL	>>>SCL	7,10
SDA	>>>SDA	7,10
URST#	>>>URST#	3
+12V	>>>+12V	7,10,13,14
TUNER_12V	>>>TUNER_12V	7
820SUP3_1	>>>820SUP3_1	3
PWR_GND	>>>PWR_GND	11
INVERTER_PWR	>>>INVERTER_PWR	11
GPIO_DVDT	>>>GPIO_DVDT	3
DV18A	>>>DV18A	2,3

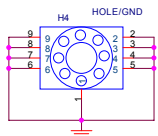
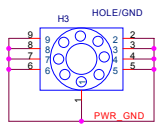
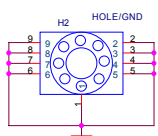
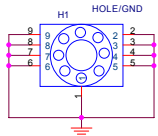
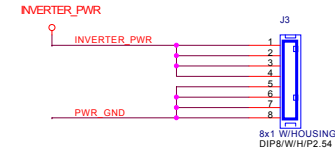
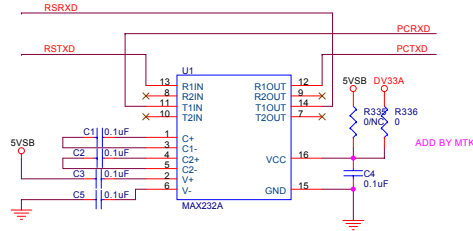
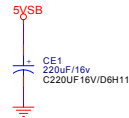

- 1 M1 1 M2 1 M3
- 1 V1 1 V2 1 V3 1 V4

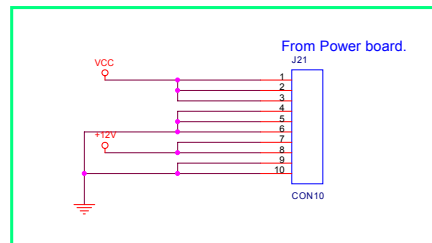
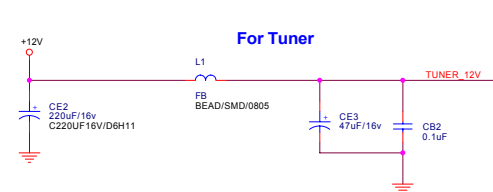
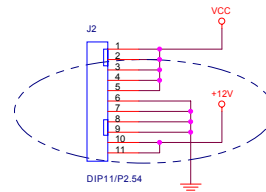
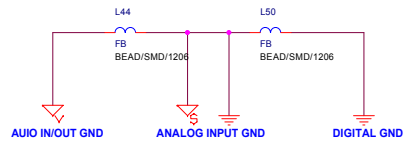
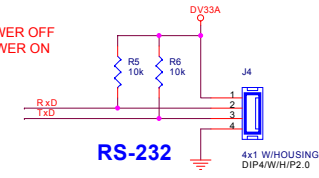
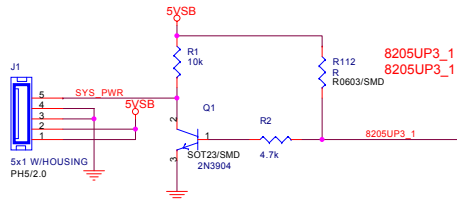
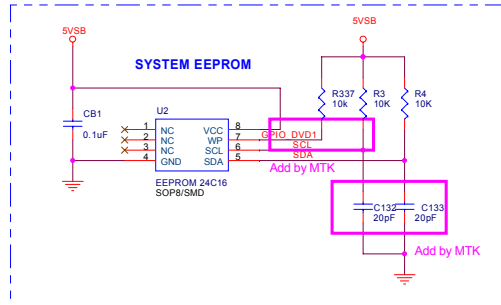

Title			
Size	Doc Number	INDEX	Rev
C			V1.2
Date:	Wednesday, October 12, 2005	Sheet 1 of 15	

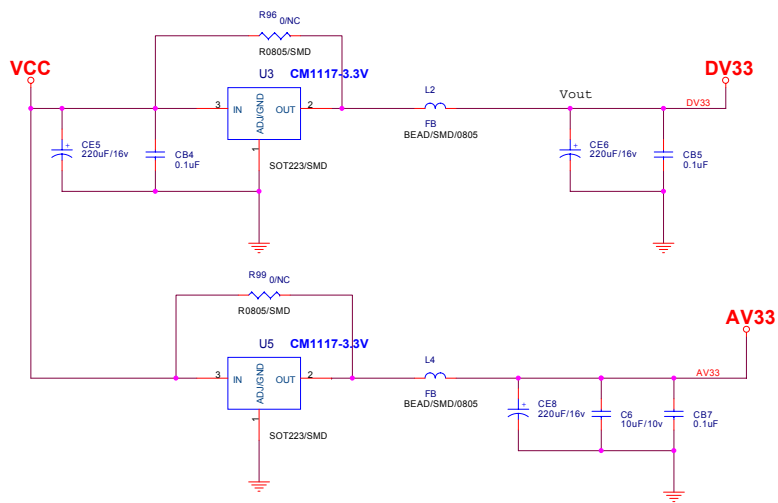

Power ON alive source

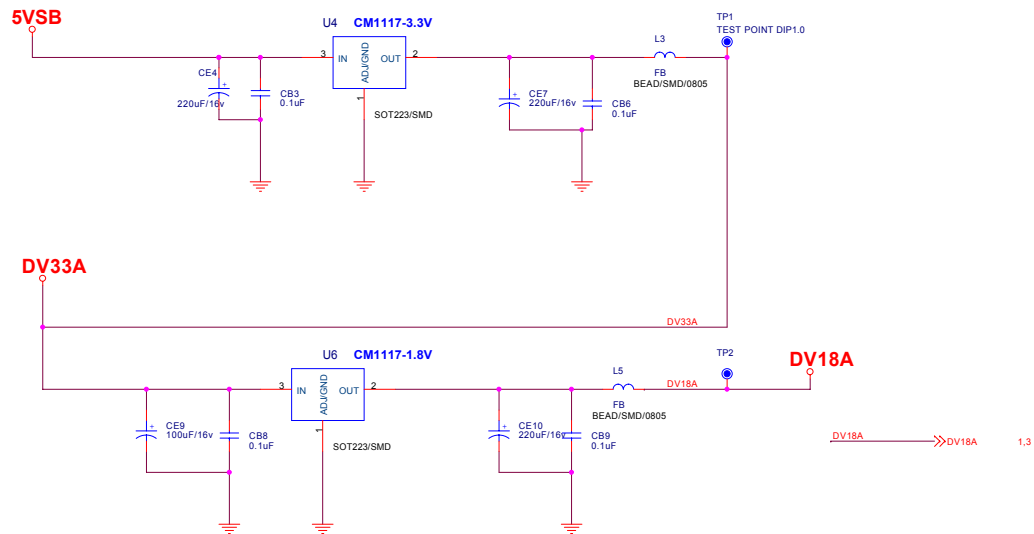

Title			
Size	Doc Number	LDO	Rev
C			V1.2
Date:	Wednesday, October 12, 2005	Sheet	2 of 15

MT8205 ANALOG DECOUPLING & DIGITAL DECOUPLING

- DV18A >> DV18A 1,2,3
- DACVREF >> DACVREF 3
- DACFS >> DACFS 3
- ADCPDLLVDD1 >> ADCPLLVD1 3
- ADCPDLLVDD >> ADCPLLVD 3
- APLLVDD >> APLLVD 3
- ANALOGVDD >> APLLVD 3
- VPLLVD >> VPLLVD 3
- LVDDA >> LVDDA 3
- ADCVD0 >> ADCVDD 3
- DACVD0 >> DACVDD 3
- AVCM >> AVCM 3
- VOCM >> VOCM 3
- VICM >> VICM 3
- VREFP4 >> VREFP4 3
- VREFN4 >> VREFN4 3
- ADCVD00 >> ADCVDD0 3
- ADCVD04 >> ADCVDD4 3
- PWM2VREF >> PWM2VREF 3
- AUXTOP >> AUXTOP 3
- AUXBOTTOM >> AUXBOTTOM 3
- REXTA >> REXTA 3
- APLL_CAP >> APLL_CAP 3
- XTALI >> XTALI 3
- XTALO >> XTALO 3

- AVCM >> CB45 4.7uF C0603/SMD GND
- VOCM >> CB46 0.1uF GND
- VICM >> CB47 0.1uF GND

- VREFP4 >> CB48 4.7uF C0603/SMD
- VREFN4 >> CB49 4.7uF C0603/SMD

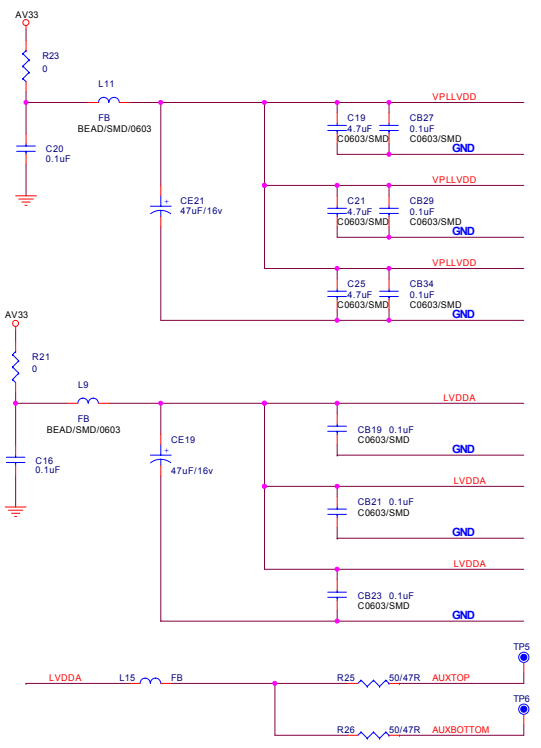
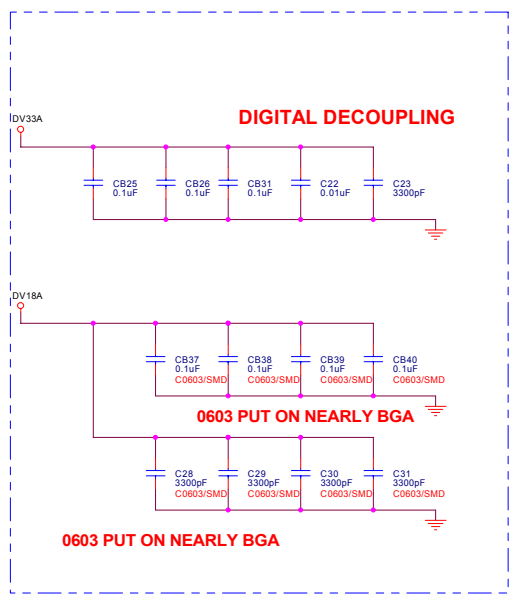
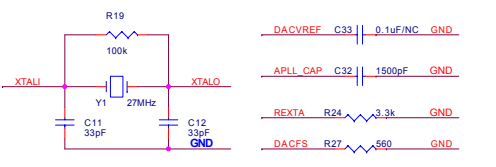
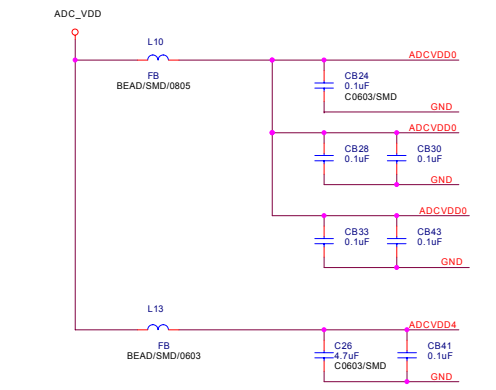
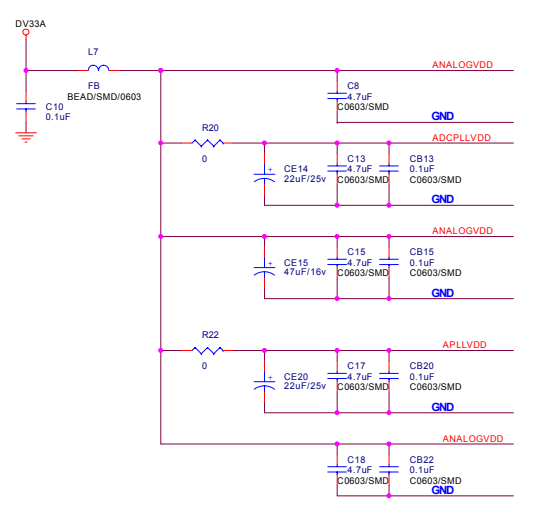
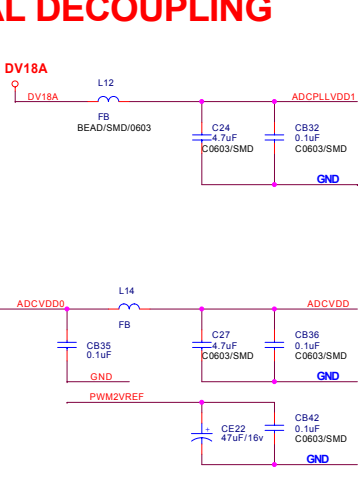
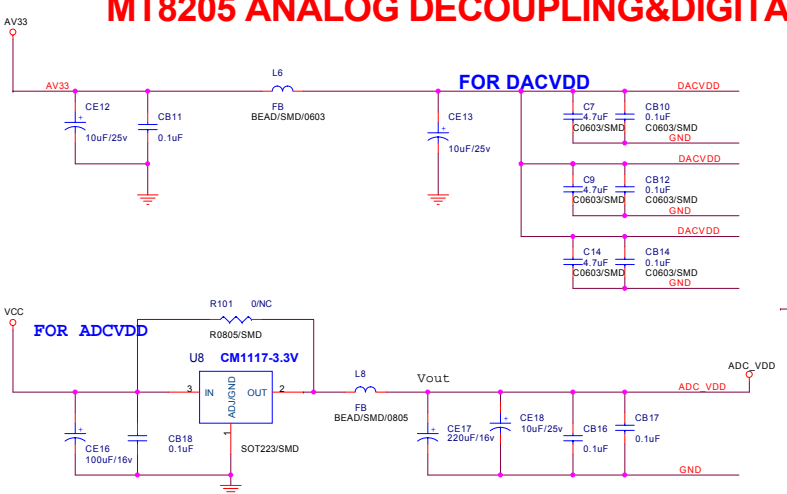

Title		
Size C	Doc Number MT8205 DECOUPOMG-ANALOG	Rev V1.2
Date: Wednesday, October 12, 2005	Sheet 4	of 15

A_DQS[0..3] A_RA[0..1] 3
 A_BA[0..1] A_RA[0..1] 3
 A_DQM[0..1] A_DQM[0..1] 3
 A_CLK A_CLK 3
 A_CLK# A_CLK# 3
 A_CKE A_CKE 3
 A_CS# A_CS# 3
 A_RAS# A_RAS# 3
 A_CAS# A_CAS# 3
 A_WE# A_WE# 3
 SDV25 SDV25 3
 VREF VREF 3
 RWR# RWR# 13
 PCE# PCE# 3
 F_DE# F_DE# 3
 F_D[0..7] F_D[0..7] 3
 F_A[0..20] F_A[0..20] 3

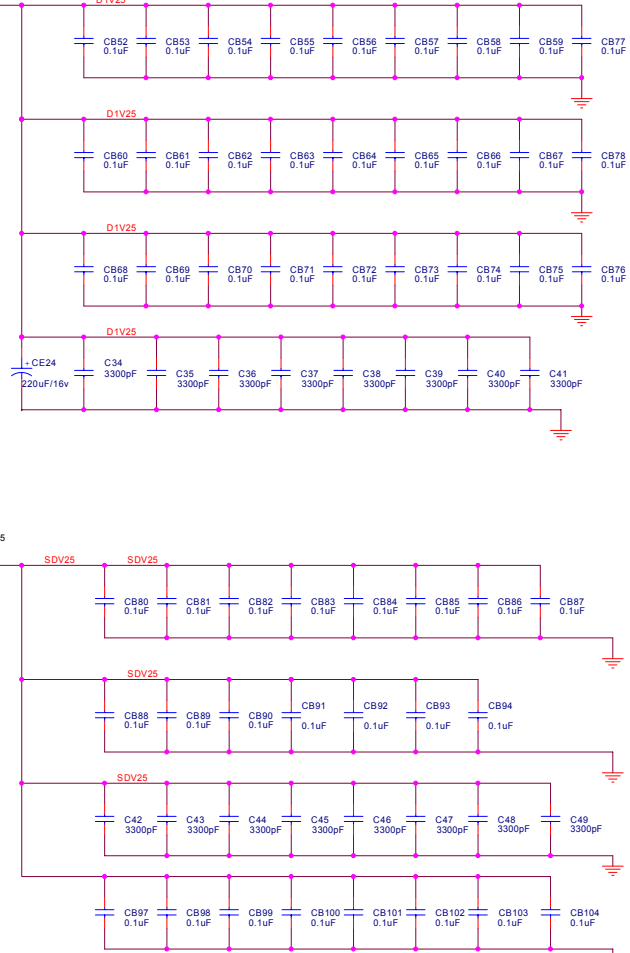
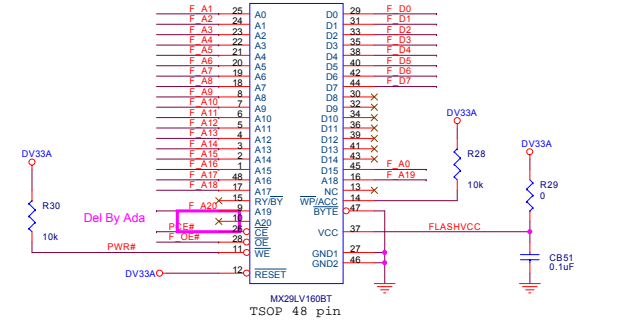
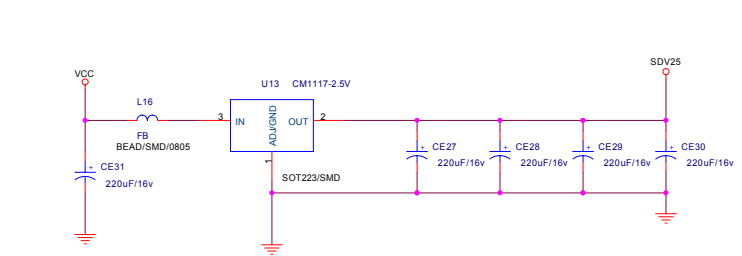
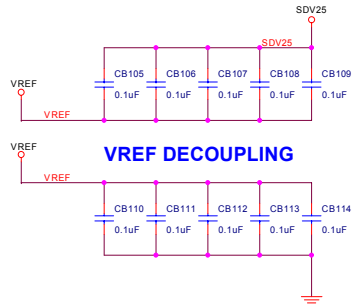
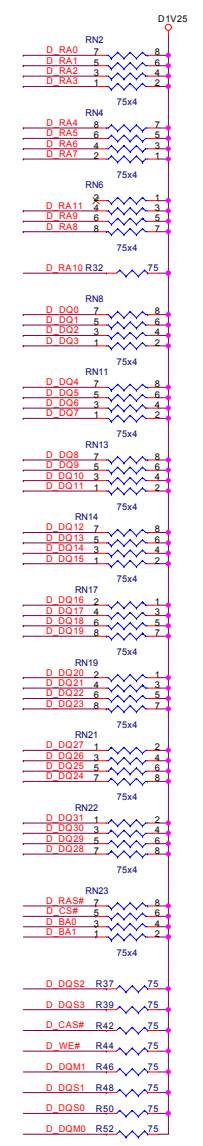
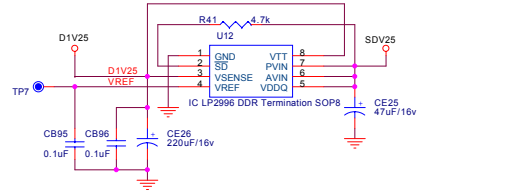
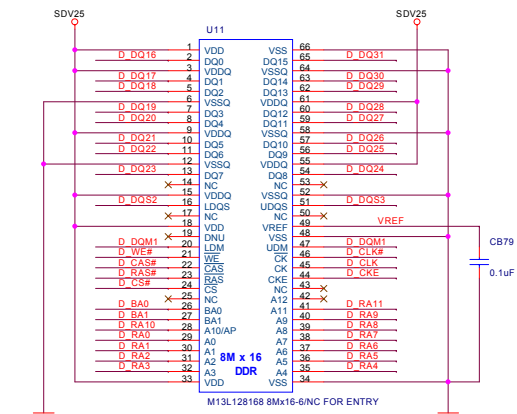
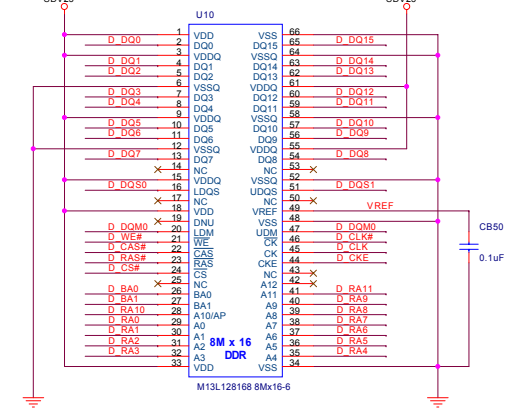
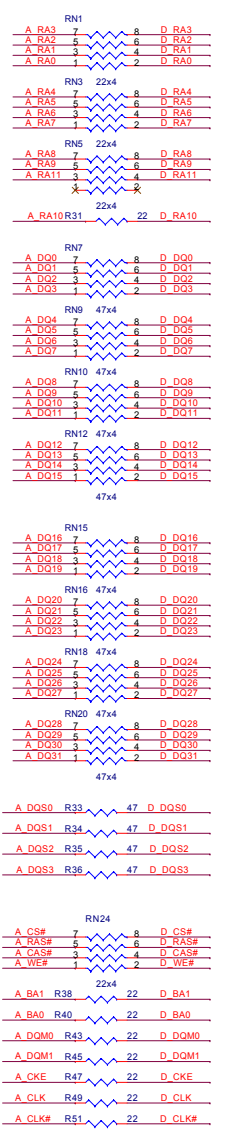

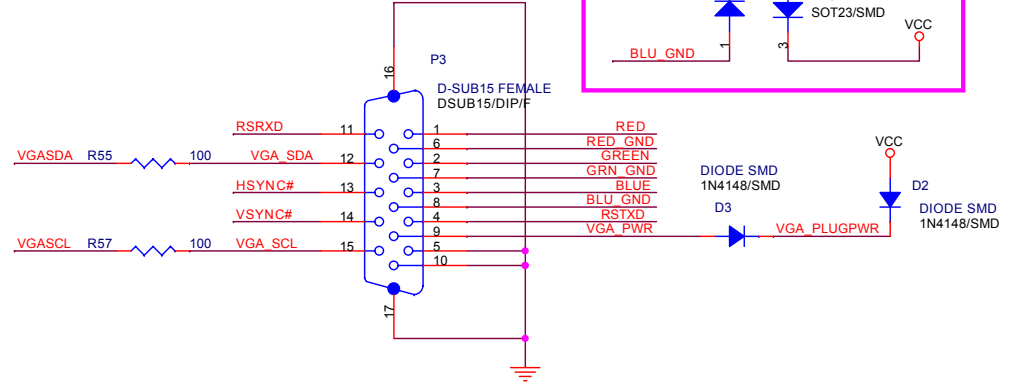
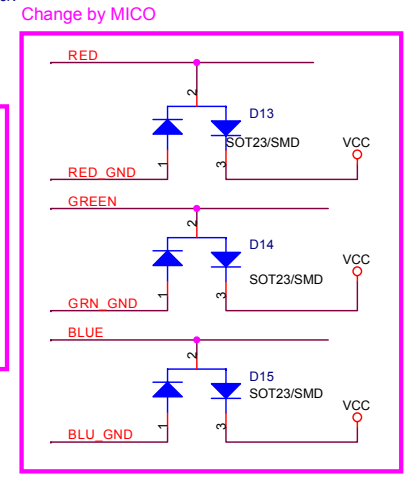
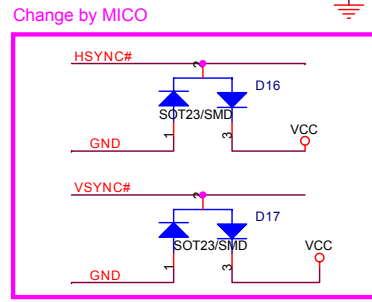
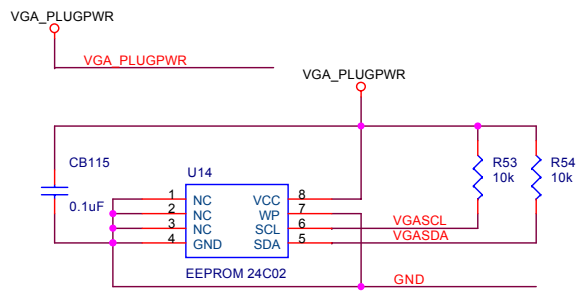
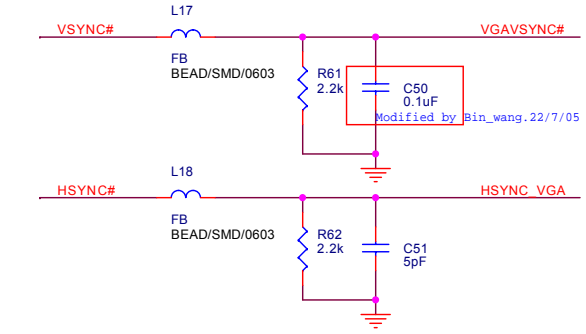
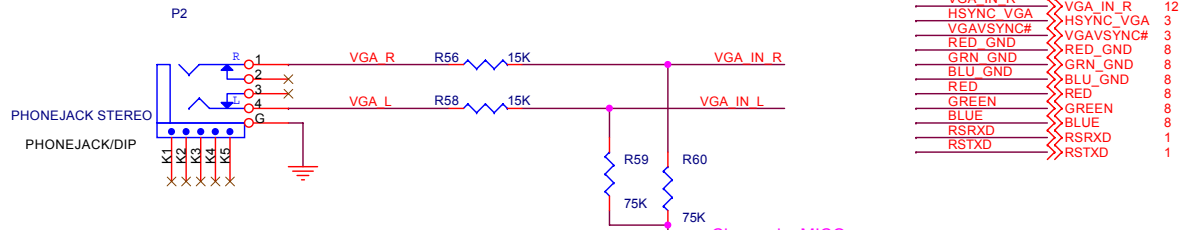

Title		
Size	Doc Number	Rev
B	VGA IN&PC AUDIO IN	V1.2
Date:	Wednesday, October 12, 2005	Sheet 6 of 15

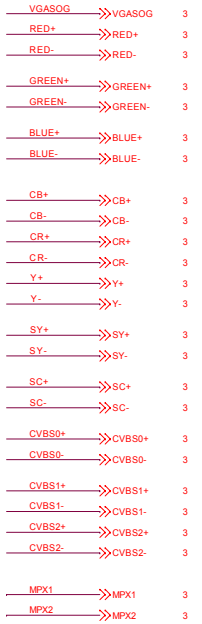

OUTPUT

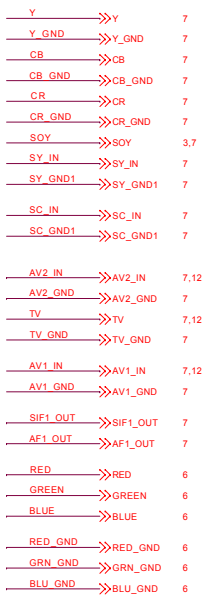

INPUT

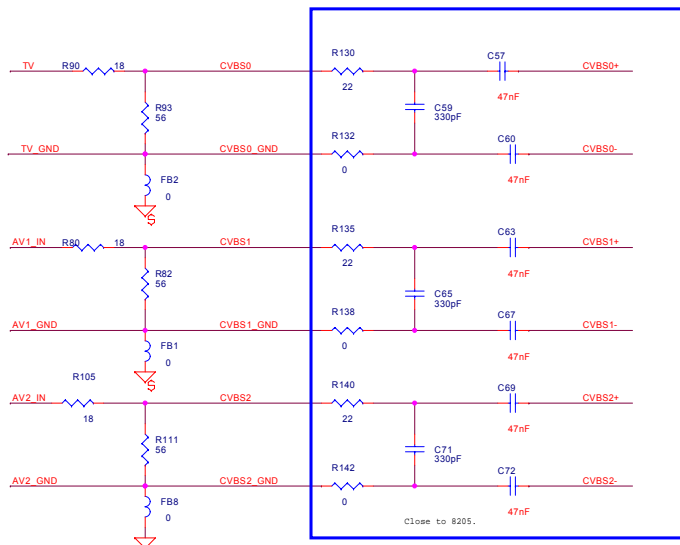

FROM Tuner

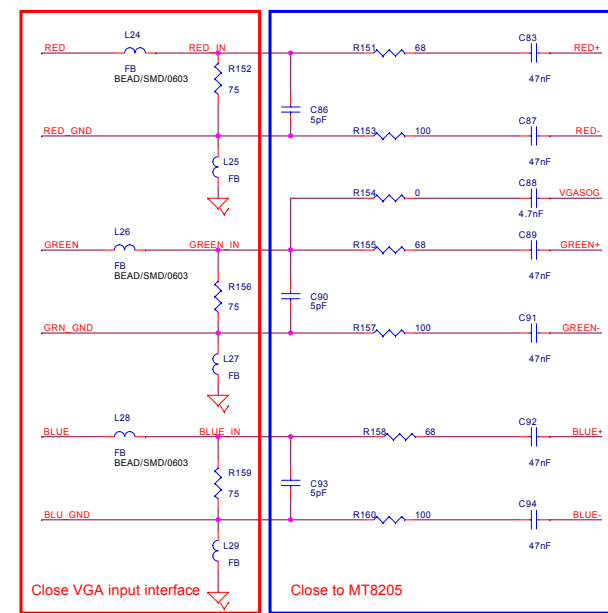
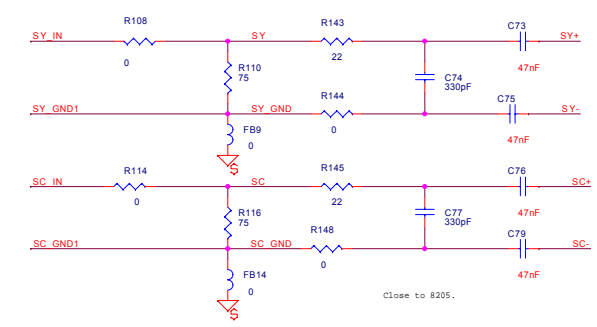
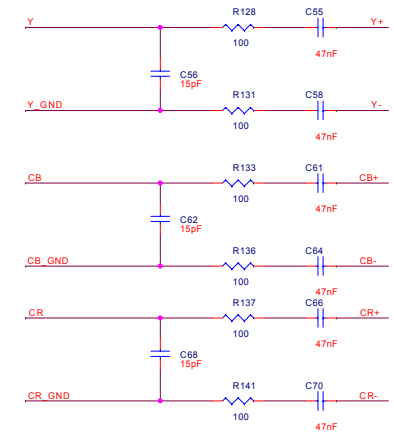
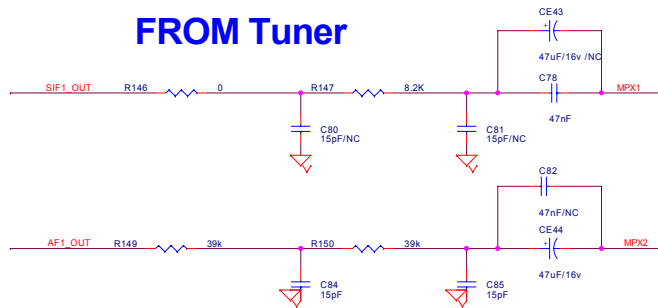

VI0_23 << VI0_23
 DVIODCK << DVIODCK
 DVIDE << DVIDE
 DVIHSYNC << DVIHSYNC
 DVIHSYNC << DVIHSYNC
 820SUP1_2 << 820SUP1_2
 OG04 << OG04
 DVISCL << DVISCL
 DVISDA << DVISDA
 F_A21 << F_A21

DVISDOT R167 R DVIPOD#
 DVICAB R177 R 0.820SUP1_2

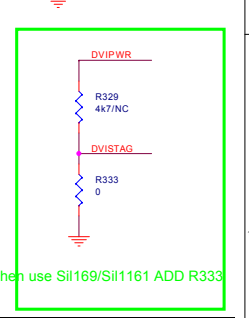
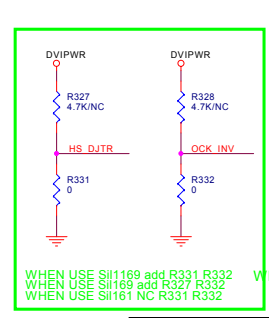
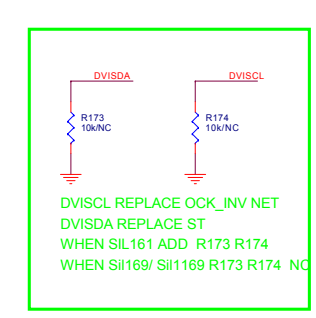
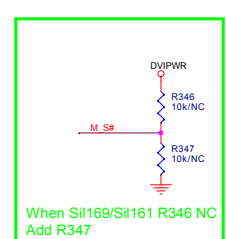
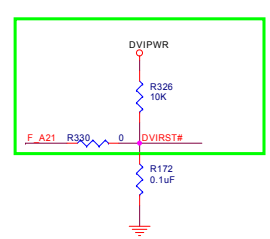
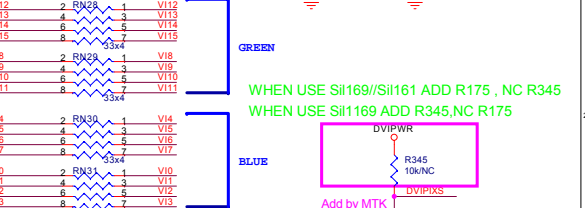
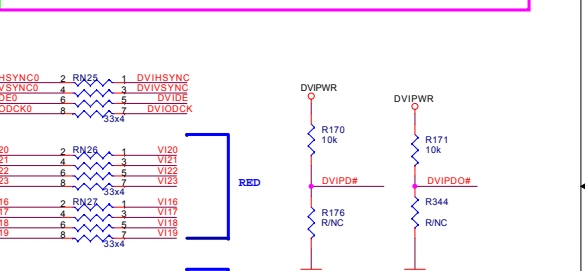
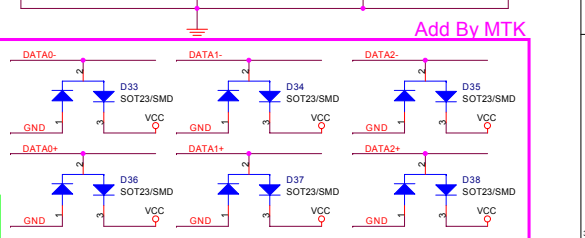
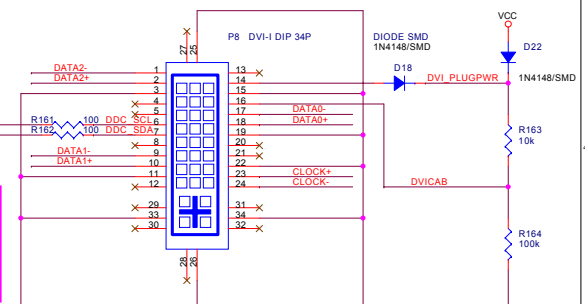
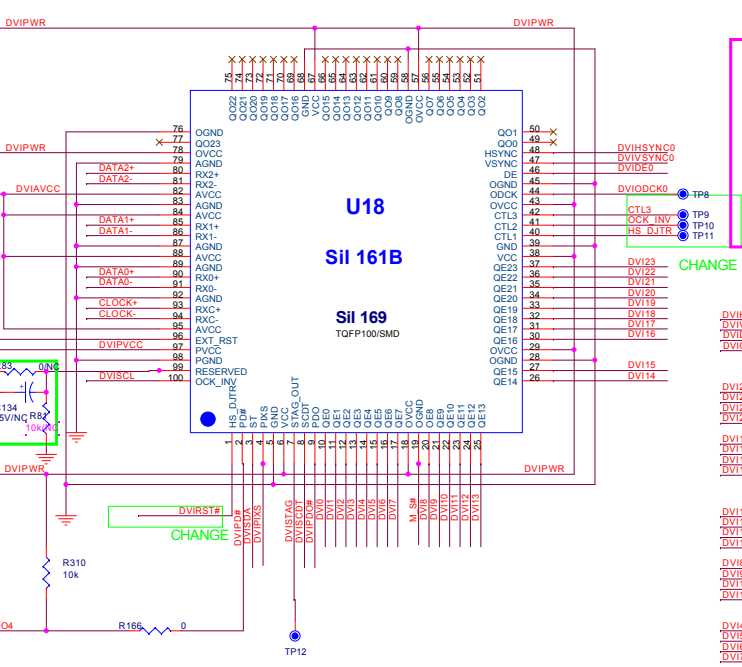
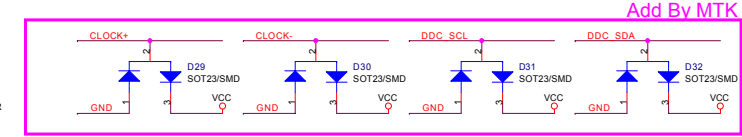
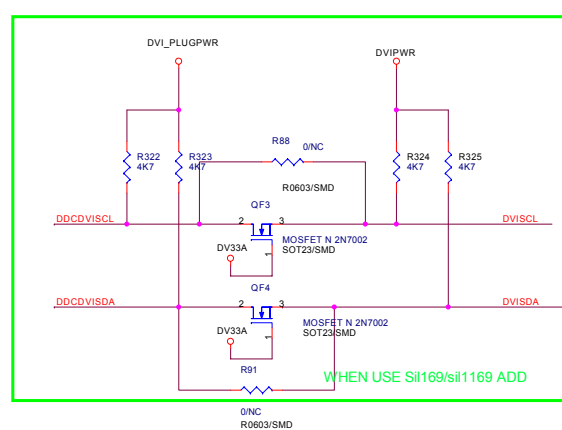
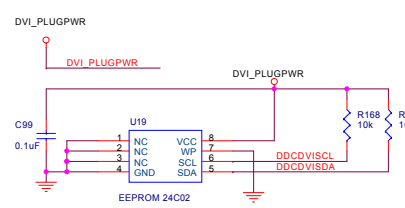
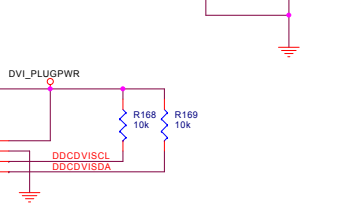
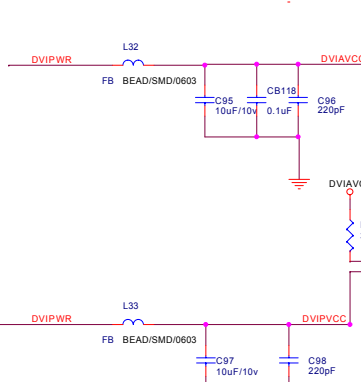
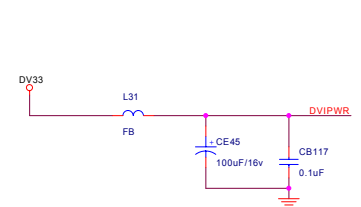
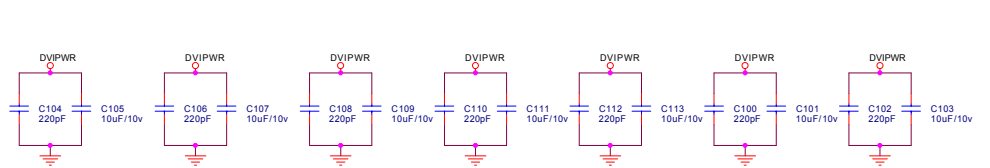

When use Sii169/Sii1169 R172 NC,Add R326
 WWhen use Sii161 R326 NC,Add R172

When Sii169/Sii161 R346 NC
 Add R347

DVISCL REPLACE OCK_INV NET
 DVISDA REPLACE ST
 WHEN Sii161 ADD R173 R174
 WHEN Sii169/ Sii1169 R173 R174 NC

WHEN USE Sii1169 add R331 R332
 WHEN USE Sii169 add R327 R332
 WHEN USE Sii161 NC R331 R332

When use Sii169/Sii1161 ADD R333

Title		
Size	Doc Number	Rev
C	DVI INPUT	V1.2
Date:	Wednesday, October 12, 2005	Sheet 9 of 15

+12V	>>>+12V	1,7,13,14
CLK1+	>>>CLK1+	3
CLK1-	>>>CLK1-	3
API0..7J	>>>API0..7J	3
AN(U..6)	>>>AN(U..6)	3
R	>>>R	3
G	>>>G	3
B	>>>B	3
VSYNC	>>>VSYNC	3
HSYNC	>>>HSYNC	3
SCL	>>>SCL	1,7
SDA	>>>SDA	1,7
OR06	>>>OR06	3
GPIO	>>>GPIO	3,7
OR01	>>>OR01	3,14
OR03	>>>OR03	3,14
OR05	>>>OR05	3
8205UP1_4	>>>8205UP1_4	3
SCL1	>>>SCL1	12
SDA1	>>>SDA1	12
SCL_8205	>>>SCL_8205	3
SDA_8205	>>>SDA_8205	3

LVDS OUT(Include PDP and 32' LCD LVDS interface)

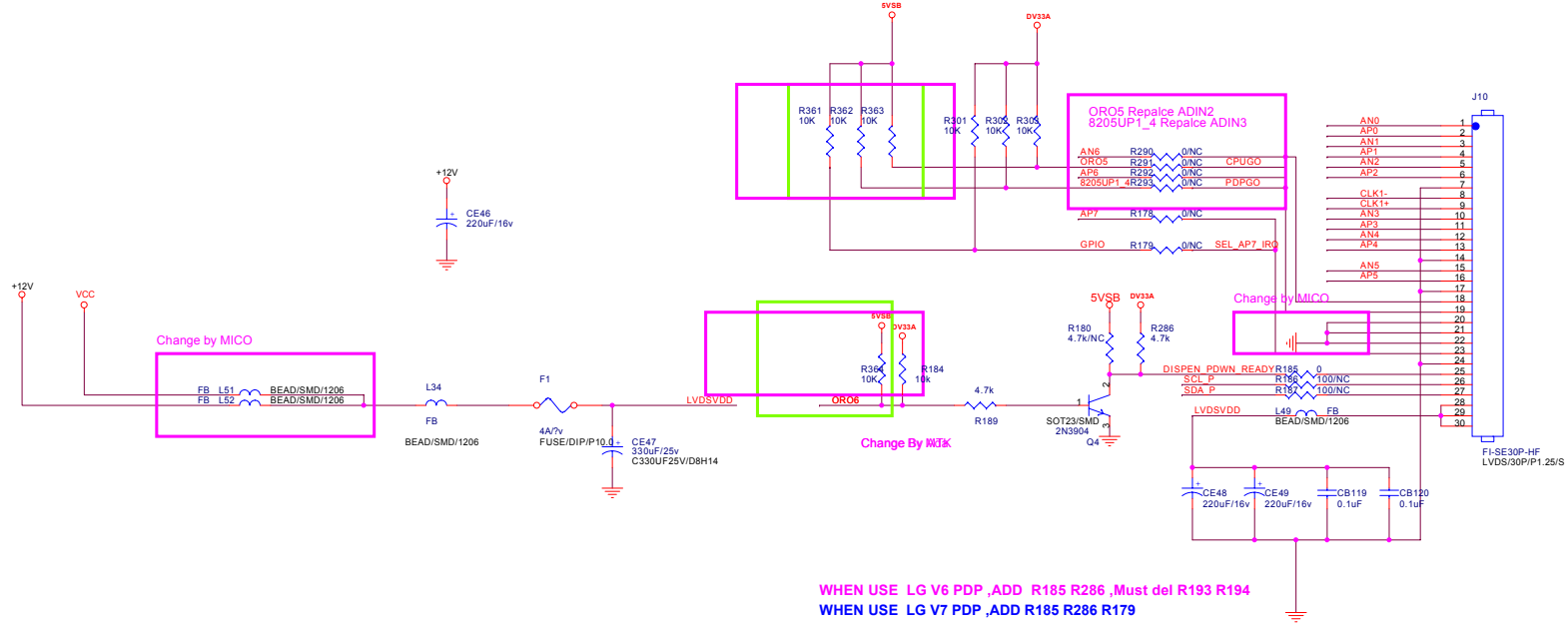

WHEN USE LG V6 PDP ,ADD R185 R286 ,Must del R193 R194
 WHEN USE LG V7 PDP ,ADD R185 R286 R179
 WHEN USE SamsungSD1 PDP ,ADD R186 R187 R185 R286
 WHEN USE Fujitsu 42 PDP ,ADD R179 R186 R187 R185 R286 R291 R293.REMOVE R178 R290 R292

**WHEN NOT USE PDP ADD L49 R178 R290 R292
 REMOVE R179 R185 R186 R187 R291 R293**

OR01	>>>OR01	3,14
OR03	>>>OR03	3,14

4.7K REPALAC 47K

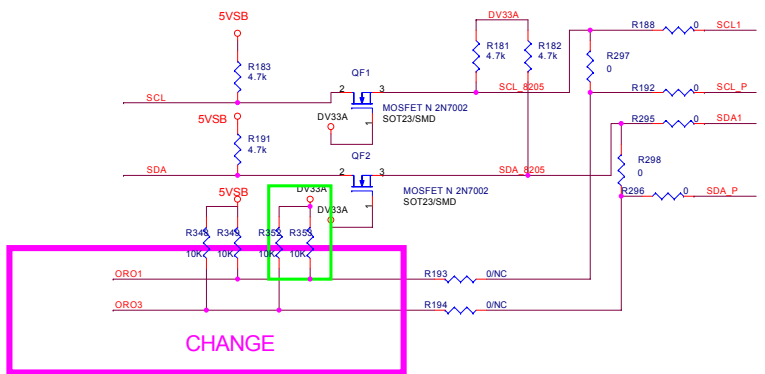

CHANGE

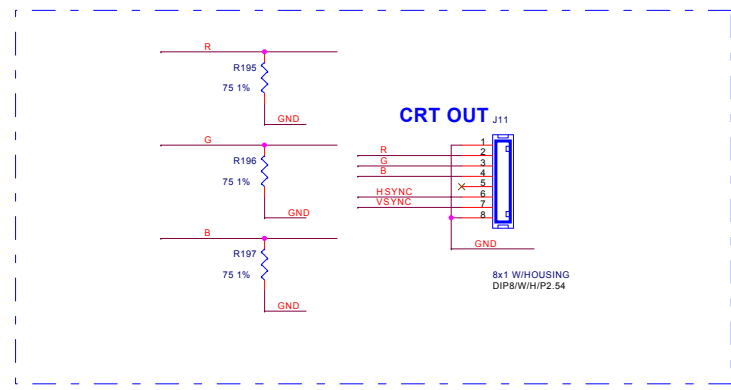

OBO[0..7]	OBO[0..7]	3
IR	IR	3.7
PWR_GND	PWR_GND	1
INVERTER_PWR	INVERTER_PWR	1
OBO0	OBO0	3
OBO1	OBO1	3
OBO2	OBO2	3
OBO3	OBO3	3
OBO4	OBO4	3
OBO5	OBO5	3
OBO6	OBO6	3
OBO7	OBO7	3
8205UP3_0	8205UP3_0	3
PWM0	PWM0	3.14
8205UP1_2	8205UP1_2	3.9
PWR_GND	PWR_GND	1

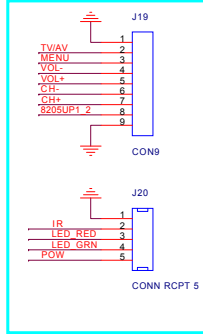
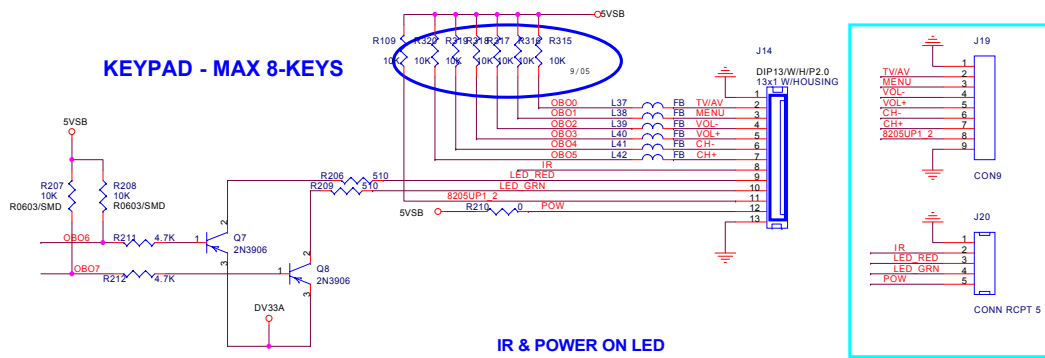
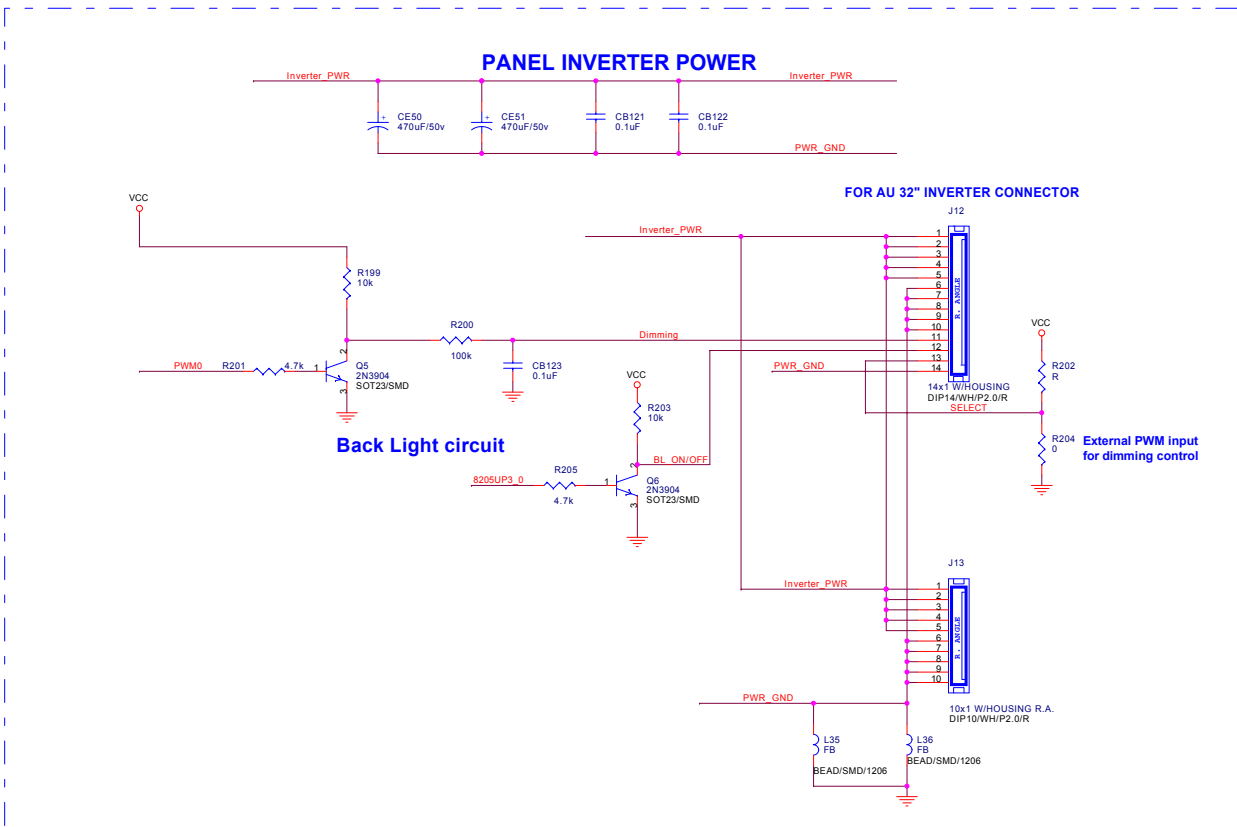

- VGA_IN_L >> VGA_IN_L 6
- VGA_IN_R >> VGA_IN_R 6
- YPBPR1_L >> YPBPR1_L 7
- YPBPR1_R >> YPBPR1_R 7
- YPBPR2_L >> YPBPR2_L 7
- YPBPR2_R >> YPBPR2_R 7
- DVI_L >> DVI_L 7
- DVI_R >> DVI_R 7
- DACSCLK >> DACSCLK 3
- DACMCLK >> DACMCLK 3
- DACLRC >> DACLRC 3
- DOUT >> DOUT 3
- AOSDATA1 >> AOSDATA1 3
- AOSDATA3 >> AOSDATA3 3

- MUTE >> MUTE 3
- PWM0 >> PWM0 3,11
- +12V >> +12V 1,7,10,13,14
- TV >> TV 7,8
- AV_L >> AV_L 7
- AV_R >> AV_R 7
- AV1_IN >> AV1_IN 7,8
- AV2_IN >> AV2_IN 7,8

- ORO4 >> ORO4 3
- ORO7 >> ORO7 3
- OS07 >> OS07 3
- PWM1 >> PWM1 10
- SCL1 >> SCL1 10
- SDA1 >> SDA1 10

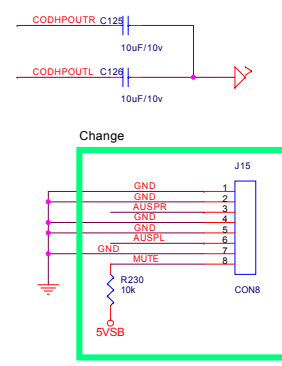
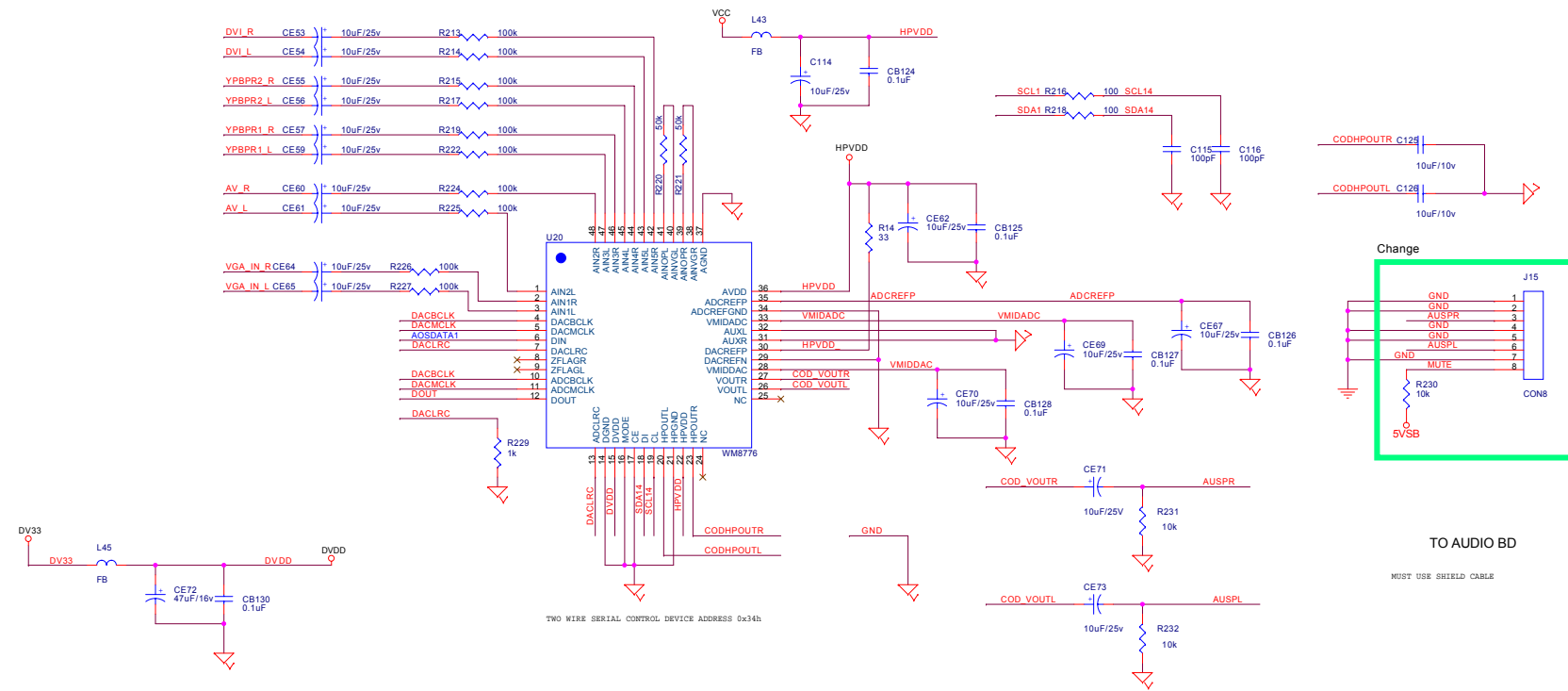

TO AUDIO BD
MUST USE SHIELD CABLE

A/V Bypass

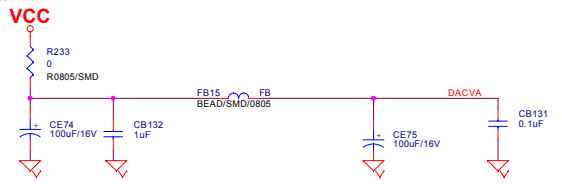

AUDIO BYPASS.

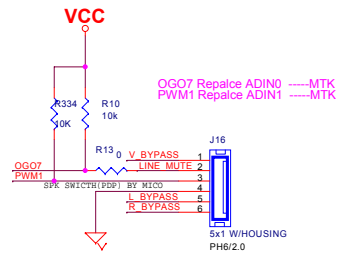
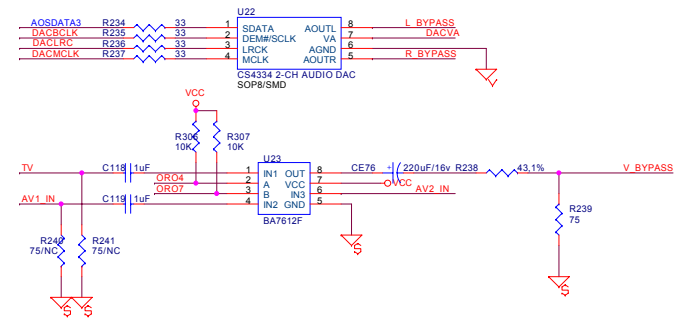

Title		
Size	Doc Number	Rev
C	WM8776/WM8766/AUDIO CODEC	V1.2
Date	Wednesday, October 12, 2005	Sheet 12 of 15

- +12V >> +12V 1,7,10,14
- TXD >> TXD 1,3
- RXD >> RXD 1,3
- DVI_VSYNC >> DVI_VSYNC 3,9
- DVI_HS_SYNC >> DVI_HS_SYNC 3,9
- DVI_DE >> DVI_DE 3,9
- DVI_ODCK >> DVI_ODCK 3,9
- 8205UP1_3 >> 8205UP1_3 3
- DAC_MCLK >> DAC_MCLK 3,12
- DAC_BCLK >> DAC_BCLK 3,12
- DAC_LRC >> DAC_LRC 3,12
- READY# >> READY# 3
- REQUEST# >> REQUEST# 3

- OGO4 >> OGO4 3,9
- OGO5 >> OGO5 3
- OGO6 >> OGO6 3,7
- VI[0..23] >> VI[0..23] 3,9
- OGO3 >> OGO3 3
- OGO1 >> OGO1 3
- OGO2 >> OGO2 3
- OGO0 >> OGO0 3
- SW >> SW 3
- PCRXD >> PCRXD 1
- PCTXD >> PCTXD 1
- WE# >> WE# 3
- PWR# >> PWR# 5

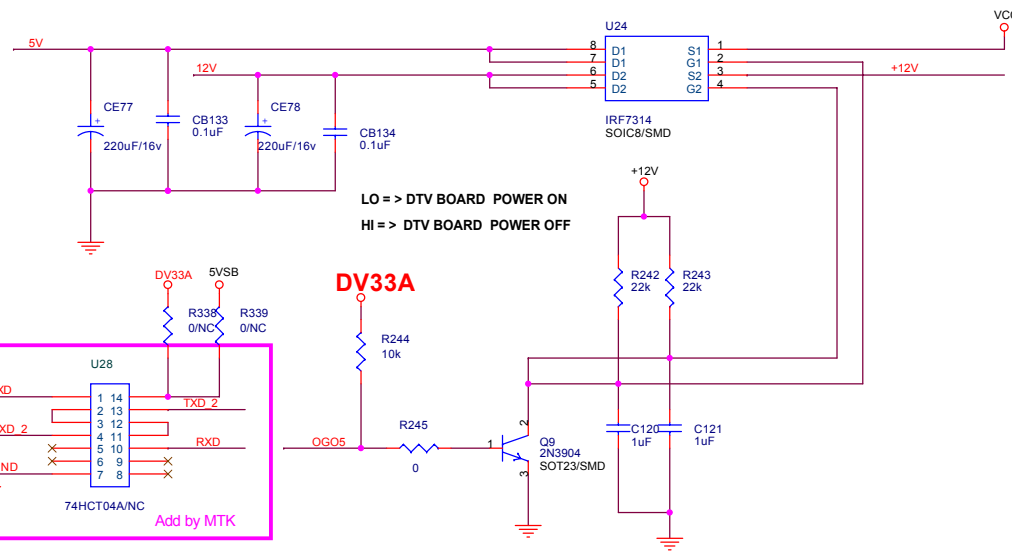

LO => DTV BOARD POWER ON
 HI => DTV BOARD POWER OFF

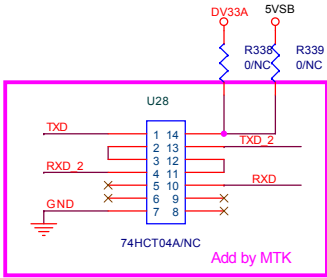

MTK Modify

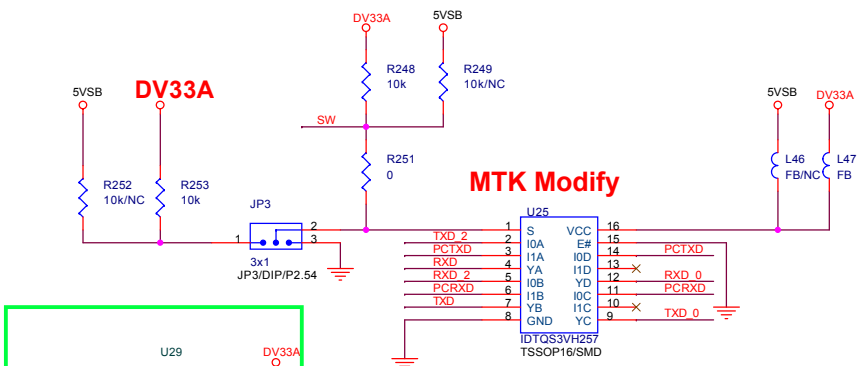

SW	Function
0	PC <--> MT5351 U0 MT5351 U2 <--> MT8205
1	PC <--> MT8205 PC <--> MT5351 U0RX

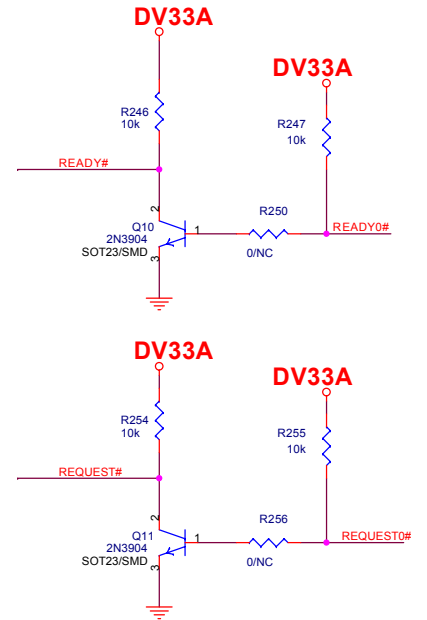

Trace width of 12V > 30mil
 Trace width of 5V > 40mil

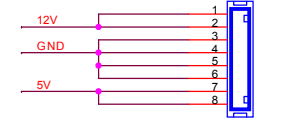

"GND Need Very Strong"

DIP8/W/H/P2.54
 TXD_0:MT5351 Transmit
 RXD_0:MT5351 Receiver
 TXD_2:MT5351 & MT8205 Communication
 RXD_2:MT5351 & MT8205 Communication

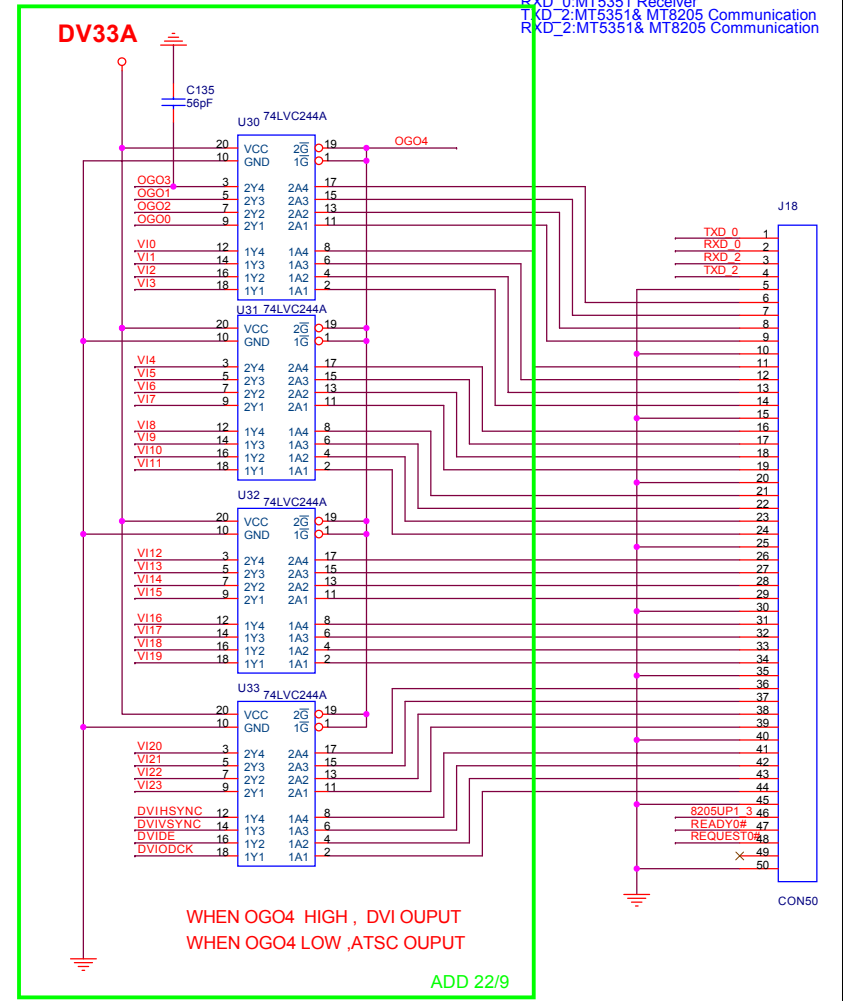

WHEN OGO4 HIGH ,DVI OUPUT
 WHEN OGO4 LOW ,ATSC OUPUT

ADD 22/9

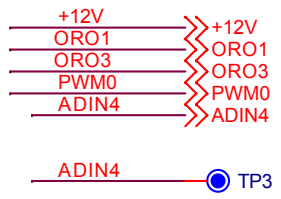

1,7,10,13
3,10
3,10
3,11
3

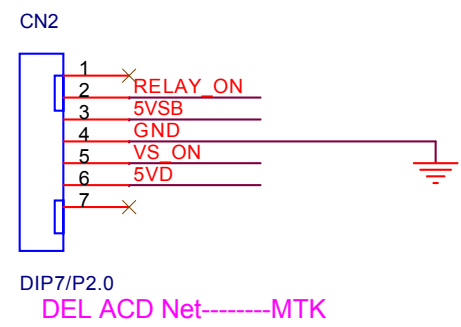

Change-----MTK

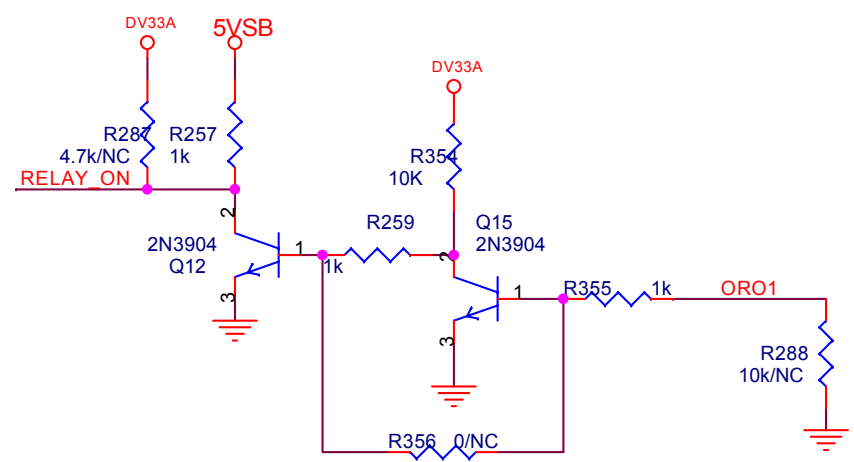
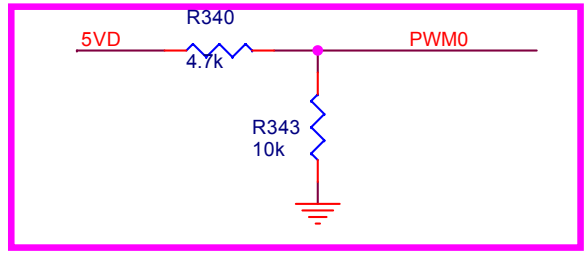

USE WHEN LG V6

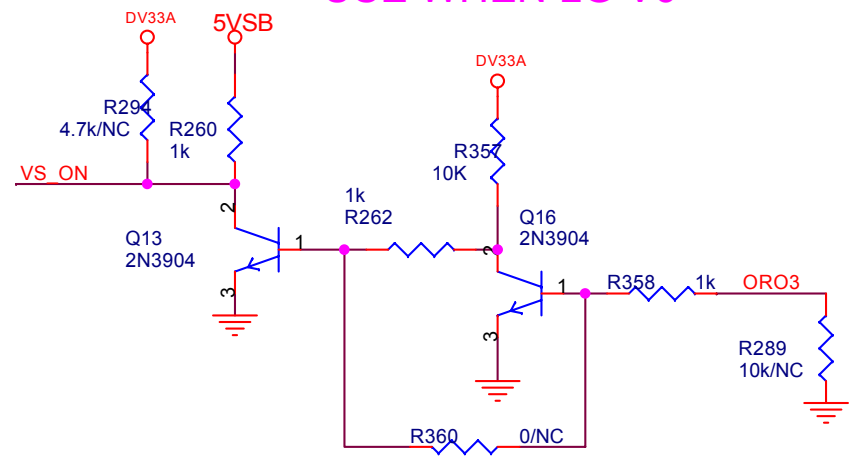

USE WHEN LG V6

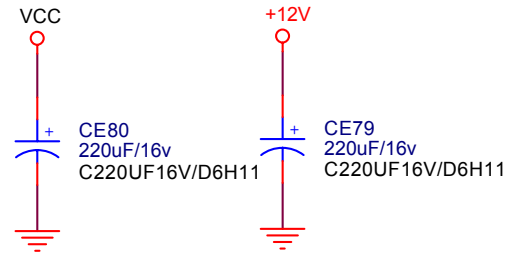

Title		
Size A	Doc Number PDP interface	Rev V1.2
Date: Wednesday, October 12, 2005	Sheet 14	of 15

From V0.1 To V1.2 change item:

- 1,Add R109-10K;R107-4.7K;C135-56pF;0603-R88,R91,R104,R106-0欧姆.0805-R96,R99,R101-0欧姆
- 2,Reset IC 增加5V Supply;DVI AUDIO ADD CONNECTOR J8.
- 3,ADIN4 CHANGE TO PWM0

Title			
Size	Doc Number	Rev	
A	History	V1.2	
Date:	Wednesday, October 12, 2005	Sheet	15 of 15

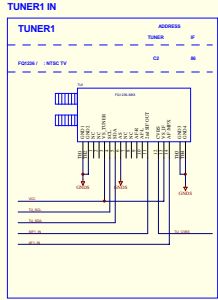

TUNER1 SIF1 BPF
NTSC 4.5MHz PAL 6MHz

AV TUNER IN

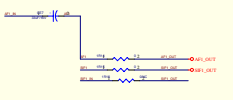
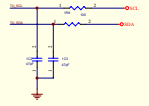
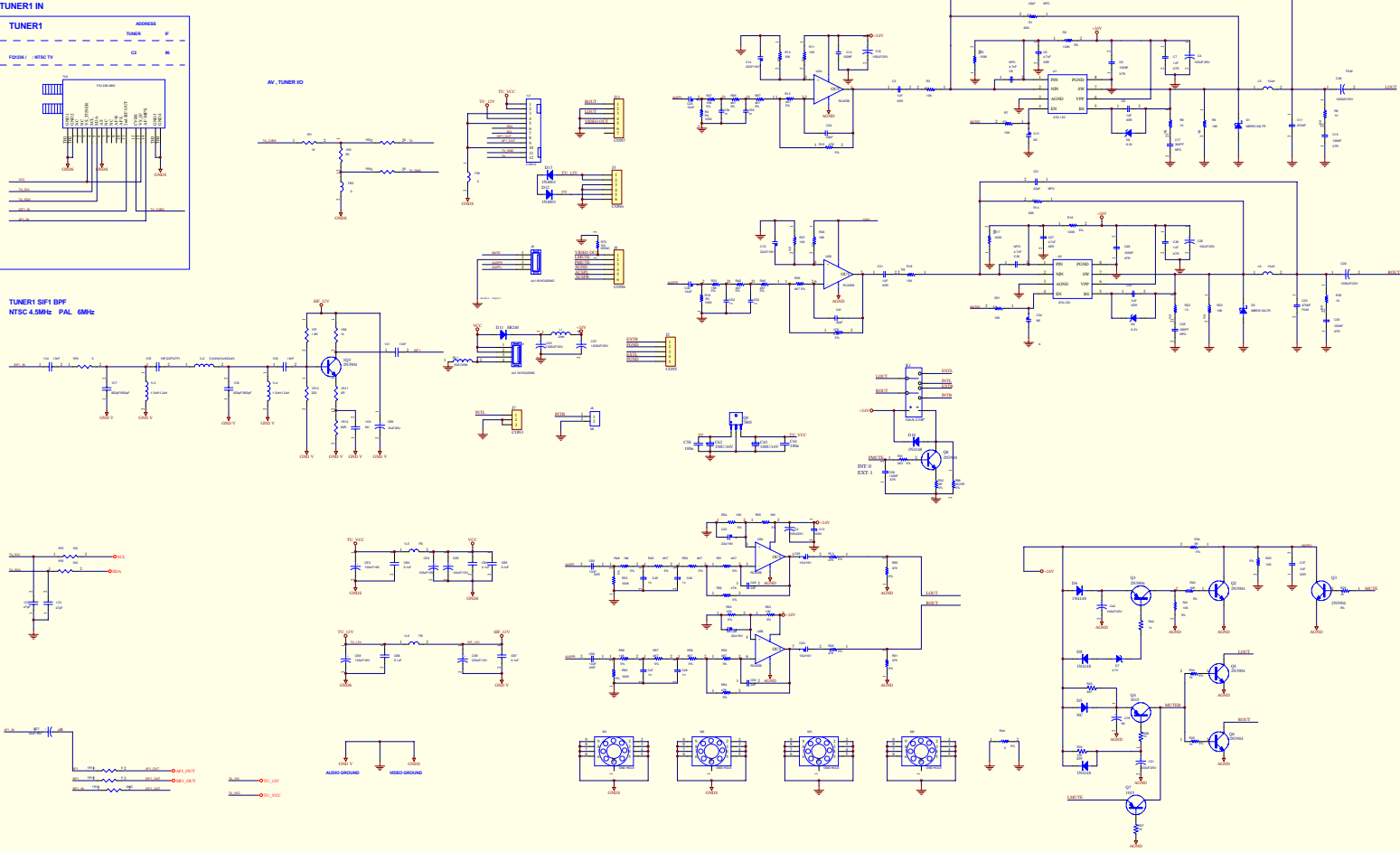

AUDIO GROUND VIDEO GROUND

REV	DATE	BY	CHKD

MT5111 / MT5351 REFERENCE DESIGN - 4 LAYERS

Rev	History	P#	DATE
RA-V1	INITIAL VERSION		2005/06/15
RA-V2	ADDED AUDIO SWITCH / REFINE POWER CIRCUIT		2005/07/14

- 01. INDEX AND INTERFACE
- 02. POWER
- 03. TUNER
- 04. MT5111 ASIC
- 05. MT5351 ASIC
- 06. MT5351 PERIPHERAL
- 07. DDR MEMORY
- 08. NOR FLASH / JTAG / UART

NS : NON-STUFF

NAME	TYPE	DEVICE
+12V	POWER +12V	POWER SUPPLY
+5V	POWER +5V	POWER SUPPLY
+5V_tuner	POWER +5V	TUNER POWER
DV33_DM	POWER +3V3	MT5111 POWER
DV18	POWER +1V8	MT5111 POWER
DV33	POWER +3V3	MT5351 POWER
AV33	POWER +3V3	MT5351 ANALOG POWER
DV25	POWER +2V5	MT5351 DDR POWER
DV12	POWER +1V2	MT5351 POWER
GND	GROUND	GROUND

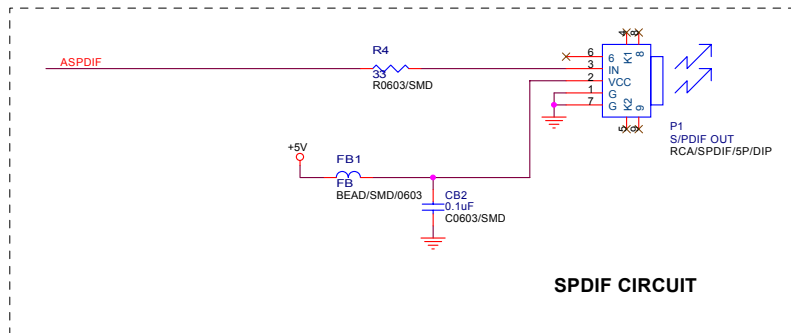
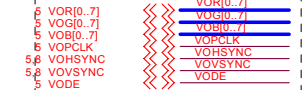
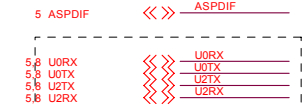
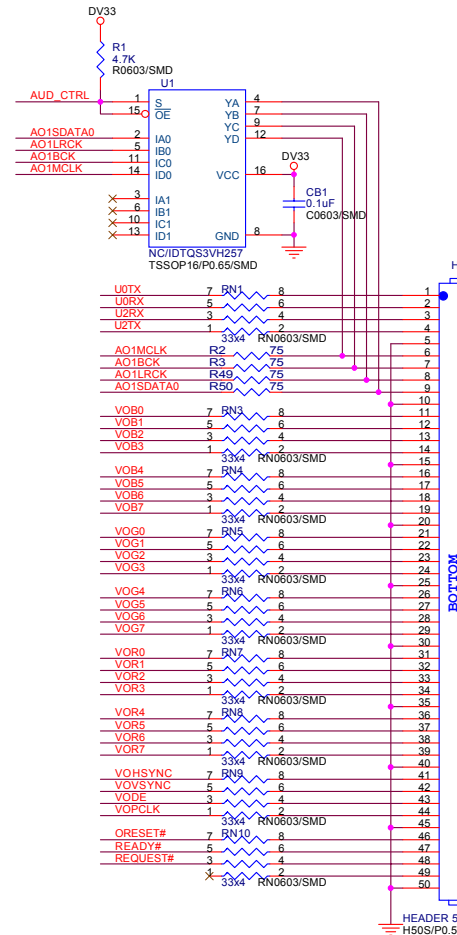
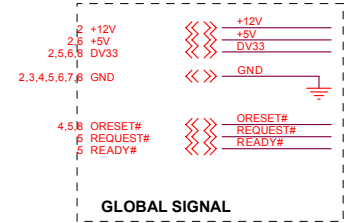
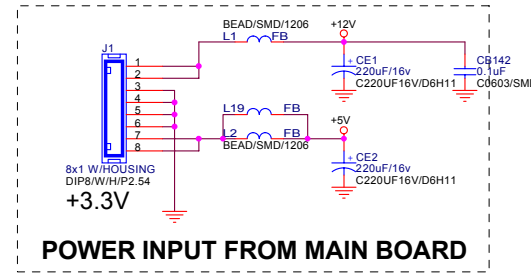

Title POWER			
Size	Document Number	Sheet	Rev
Date		of	

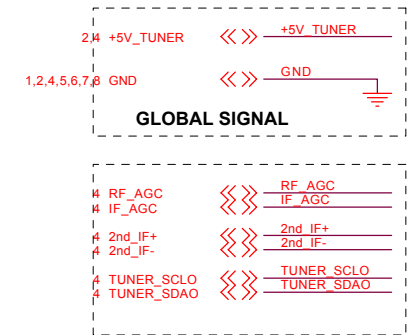
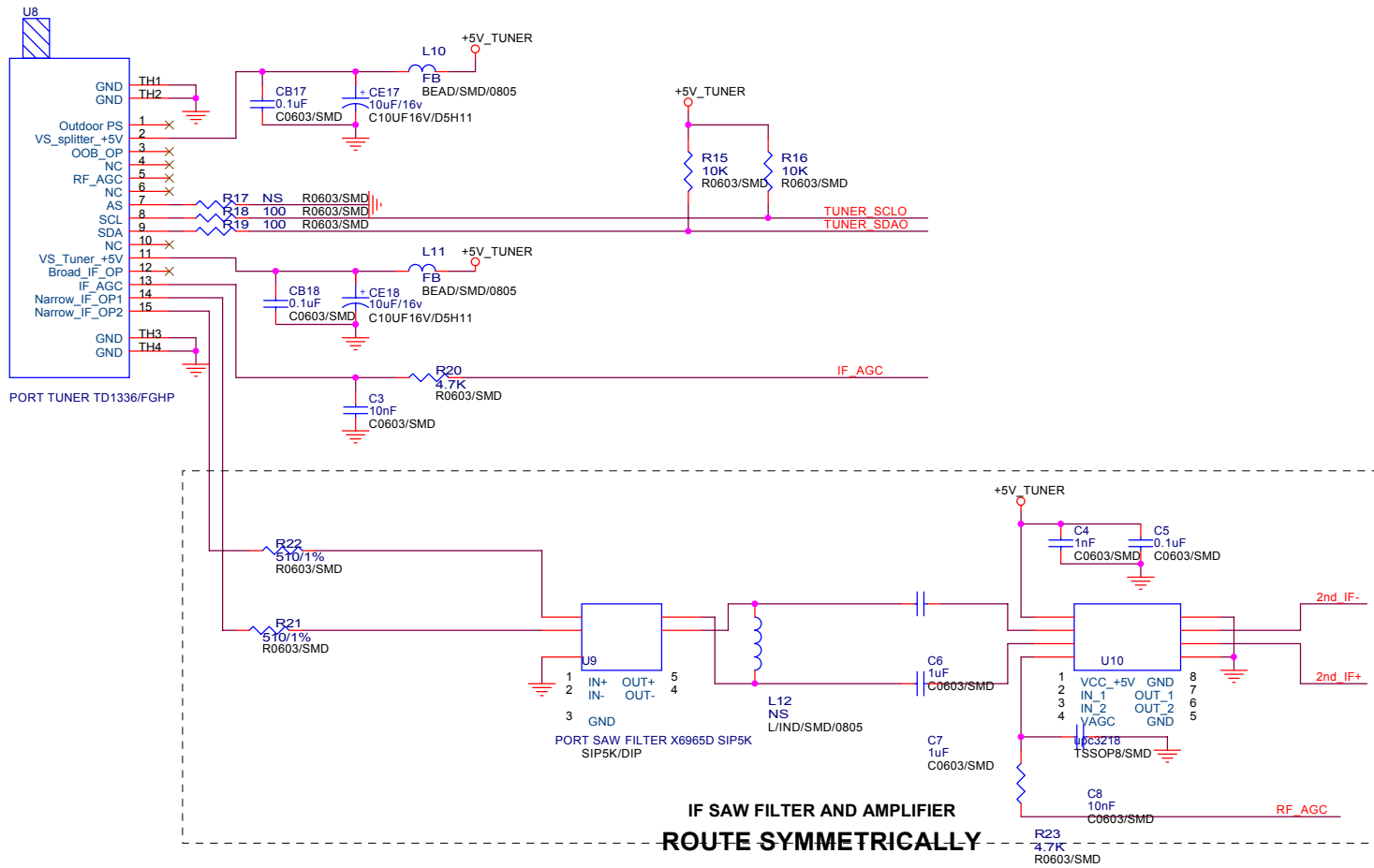

Title			TUNER		
Size	Document Number				Rev
Custom	MT5351RA-V2				1
Date:	Monday, September 26, 2005		Sheet	3	of 8

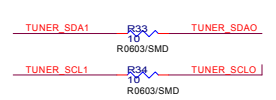
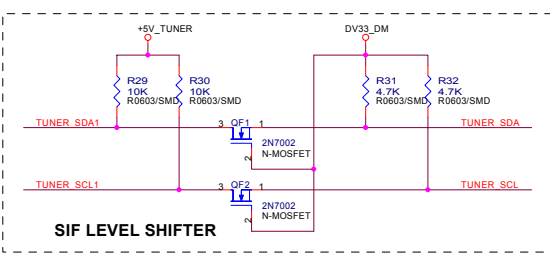
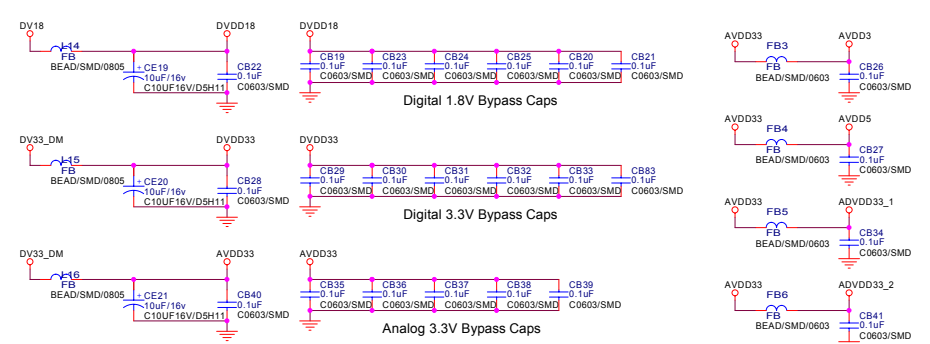
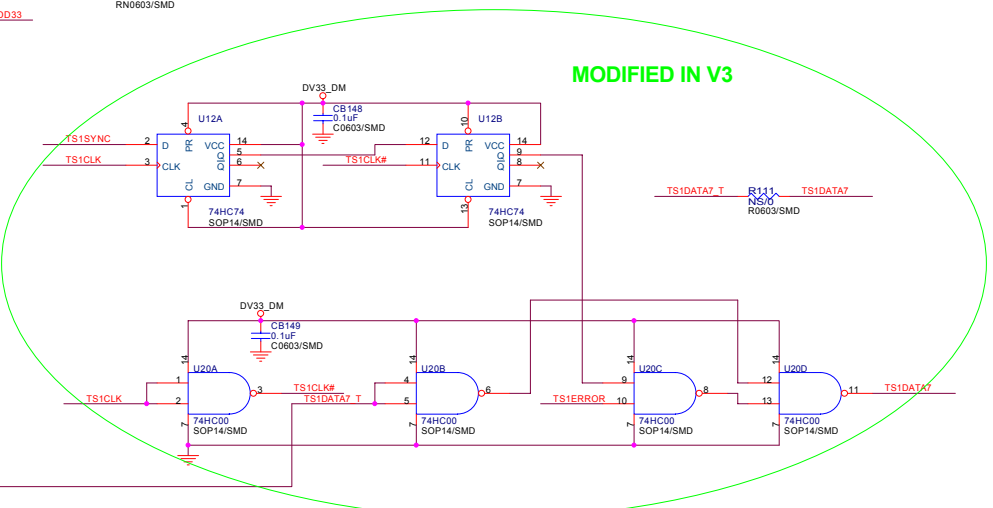
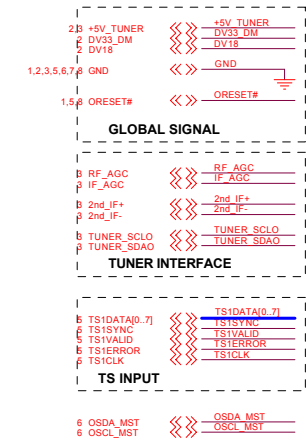
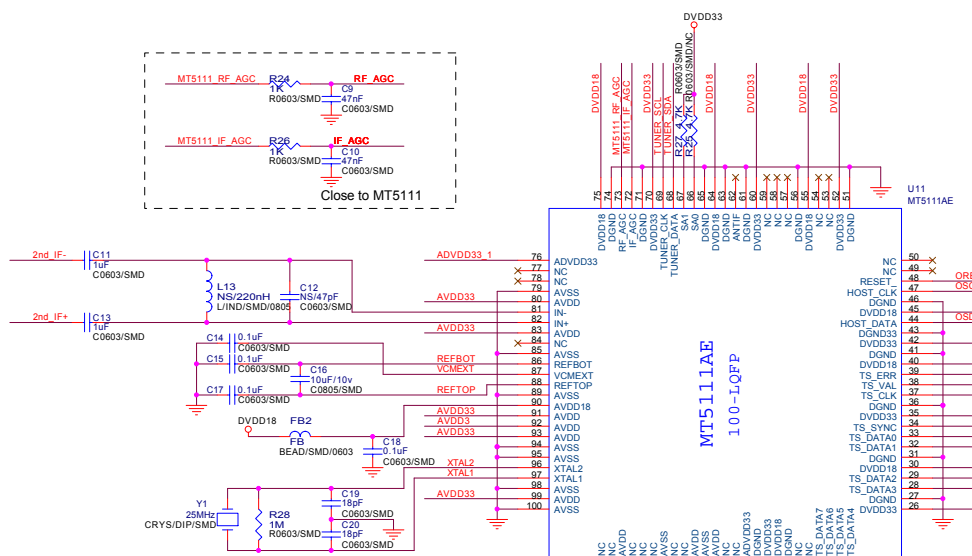
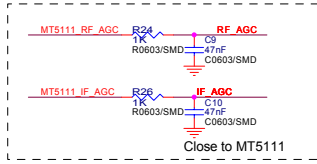

Title			
MT5111 ASIC			
Size		Document Number	
C		MT5351RA-V2	
Date:	Monday, September 28, 2005	Sheet	4 of 8
			Rev 1
			TwinSon Chan

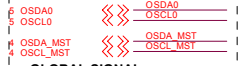
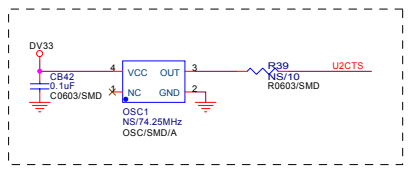
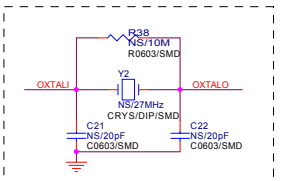
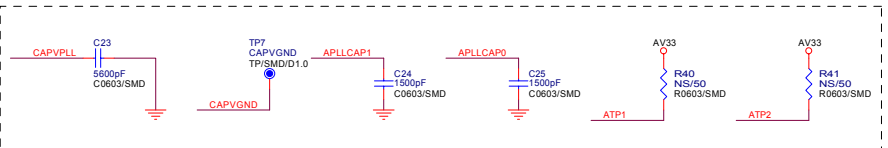
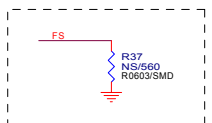

GLOBAL SIGNAL

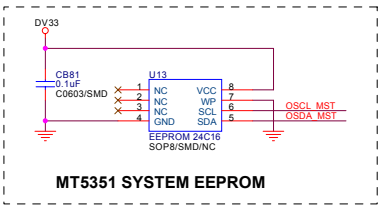
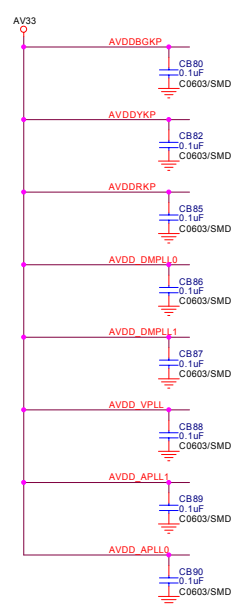
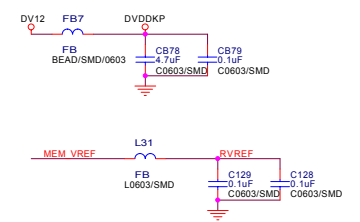
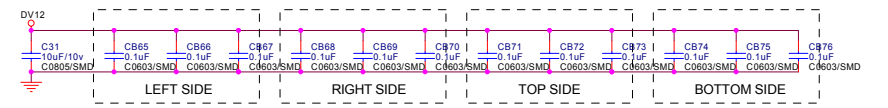
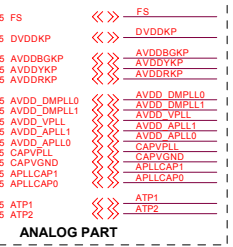
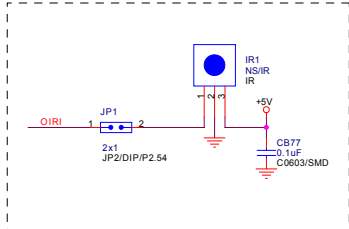
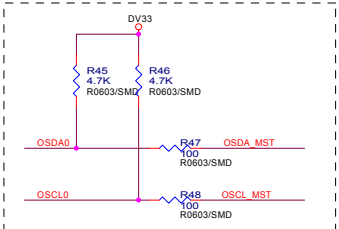
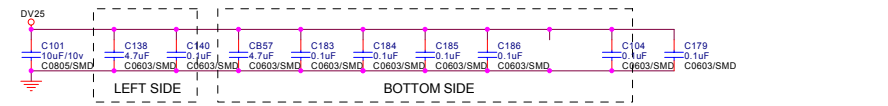
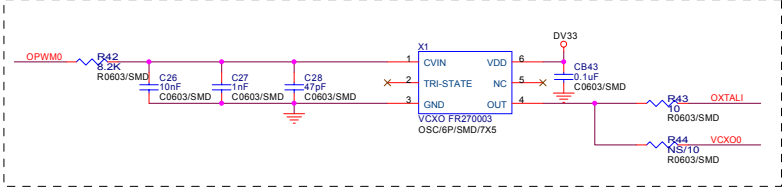
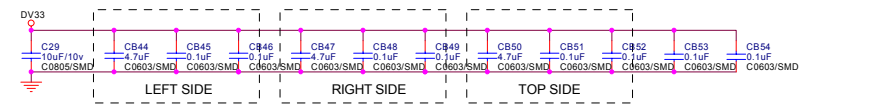

Title			MT5351 PERIPHERAL		
Size	Document Number				Rev
Custom	MT5351RA-V2			TwinSon Chan	1
Date:	Monday, September 26, 2005	Sheet	6	of	8

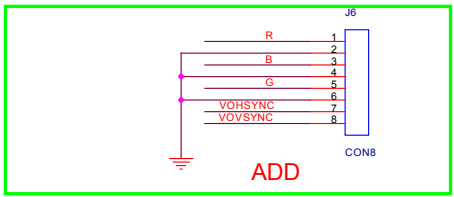
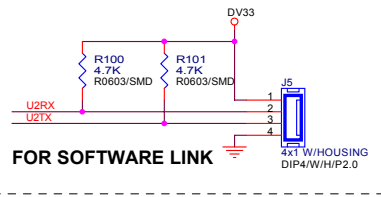
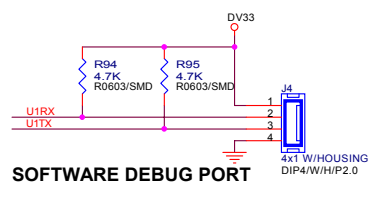
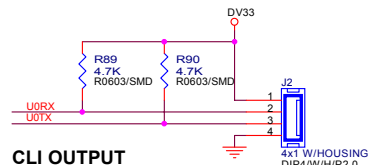
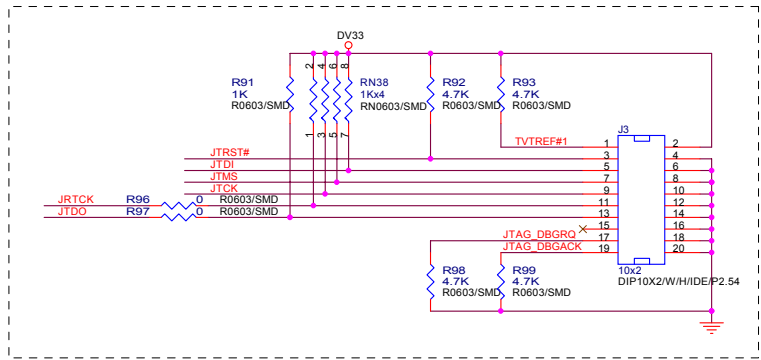
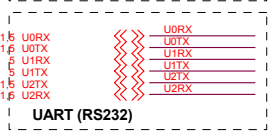
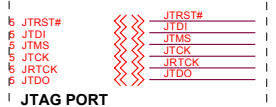
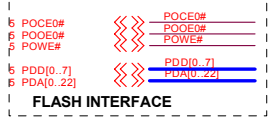
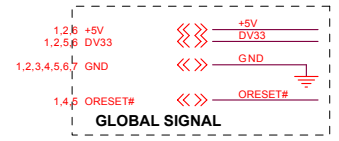
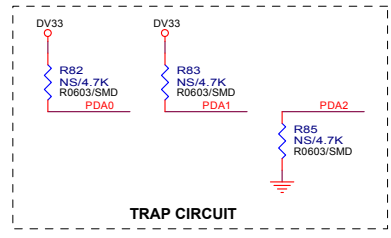
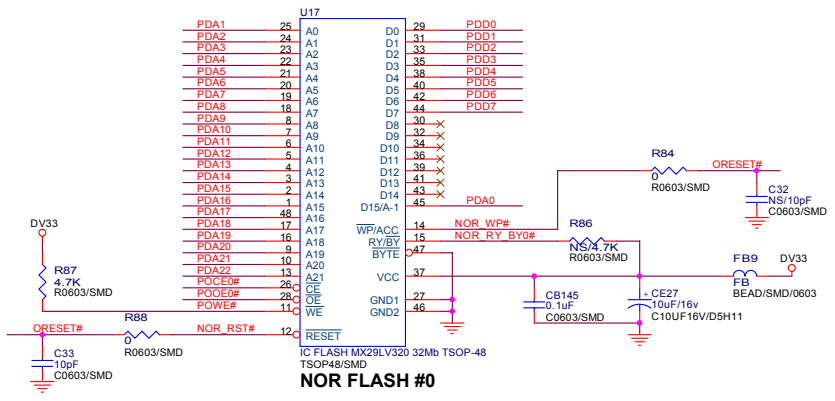

Title			
NOR FLASH / JTAG / UART			
Size	Document Number	Rev	
Custom	MT5351RA-V2	1	
Date:	Monday, September 26, 2005	Sheet	8 of 8
		TwinSon Chan	

Basic Operations & Circuit Description

MODULE

There are 1 pcs panel and 8 pcs PCB including 2 pcs Y/Z Sustainer board, 2 pcs Y Drive board, 2 pcs X (left and right) Extension PCB, 1 pcs Control (Signal Input) and 1 pcs Power board in the Module.

SET

There are 6 pcs PCBs including 1 pcs Tuner/Audio board, 1 pcs Keypad board, 1 pcs Remote Control Receiver board, 1 pcs L/R Speakers and 1 pcs Main (Video) board, 1 pcs ATSC 1 pcs ATSC board in the SET.

Parts position

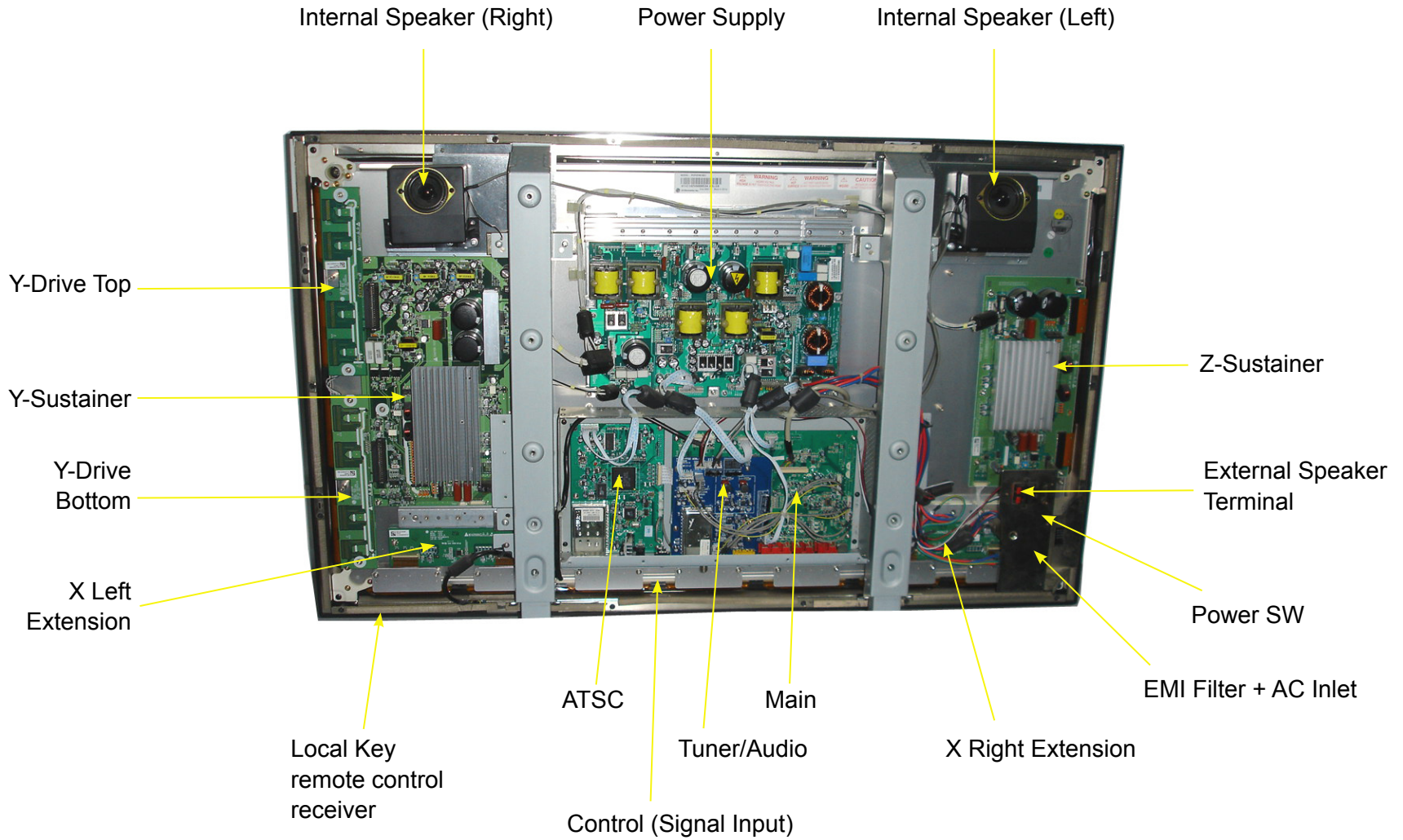

PCB function

1. Power:

(1). Input voltage: AC 110V~240V, 47Hz~63Hz.

Input range: AC 90V(Min)~265V(Max) auto regulation.

(2). To provide power for PCBs.

- ### **2. Main board: To converter TV signals, S signals, AV signals, Y Pb/ Cb Pr/Cr signals, DVI signals and D-SUB signals to digital ones and to transmit to Control board.**
- ### **3. Control board: Dealing with the digital signal for output to panel.**
- ### **4. Y-Sustainer / Z-Sustainer board:**
- (1). Receiving the signals from Control and high voltage supply.**
- (2). Output scanning waveform for Module.**
- ### **5. Y-Drive board: Receive signal from Y sustainer, output horizontal scanning waveform to the panel.**
- ### **6. X (left and right) extension board: Output addressing signals.**
- ### **7. Tuner/Audio Board: Amplifying the audio signal to the internal or external speakers of which selected.**
- To convert TV RF signal to video and SIF audio signal to Main board.**
- ### **8. ATSC Board: Receiver and converter ATSC TV signal to transmit to main board.**

PCB failure analysis

- 1. CONTROL: a. Abnormal noise on screen. b. No picture.**
- 2. MAIN : a. Lacking color, Bad color scale.
b. No voice.
c. No picture but with signals output, OSD and back light.
d. Abnormal noise on screen.**
- 3. POWER: No picture, no power output.**
- 4. Z - Sustainer: a. No picture.
b. Color not enough.
c. Flash on screen.**
- 5. Y - Sustainer: Darker picture with signals.**
- 6. Tuner/Audio : a. No voice. (Make sure status: Mute / Internal, External speaker)
b. Noise
c. No ATV signals**
- 7. Y/Z - Sustainer: The component working temperature is about 55°C.
If the temperature rises abnormal, this may be a error point.**
- 8. ATSC: a. No ATSC TV signal**

Basic operation of Plasma Display

- 1. After turning on power switch, power board sends 5Vst-by Volt to Main IC MT8205 waiting for ON signals from Key Switch or Remote Receiver.**
- 2. When the ON signal from Key Switch or Remote Receiver is detected, MT8205 will send ON Control signals to Power. Then Power sends (5Vsc, 9Vsc, 12Vsc, 24V and RLY ON, Vs ON) to PCBs working. This time VIF will send signals to display back light, OSD on the panel and start to search available signal sources. If the audio signals input, them will be amplified by Audio AMP and transmitted to Speakers.**
- 3. If some abnormal signals are detected (for example: over volts, over current, over temperature and under volts), the system will be shut down by Power off.**

Main IC Specifications

- MT8205**
- Sil169**
- M13S128168A**
- MP7720**



Specifications are subject to change without notice

History

2004/09/12	Runma Chen	for customer design-in	V1.0
2004/09/30	Dragon Chen	Add feature list	V1.1
2004/09/30	Runma Chen	Modify for PIP/POP 444 support	V1.2
2004/10/01	Runma Chen	PIP/POP hardware limitation-I	V1.3
2004/10/18	Dragon Chen & Wen Hsu	PIP/POP hardware limitation-II & video front end component	V1.4
2004/10/20	Dragon Chen	Update functional block	V1.5
2004/10/21	Dragon Chen	Correct function block fault to V1.4	V1.6
2004/11/04	Dragon Chen	<ol style="list-style-type: none"> 1. Delete power spec. (About power spec, please reference another document) 2. Add AC & DC characteristics 3. Add pin description 4. Add audio out mapping rule 	V1.7
2004/11/05	Dragon Chen	Descript more detail for pin power initial state & remove some description to another document (MT8205 product brief)	V1.8

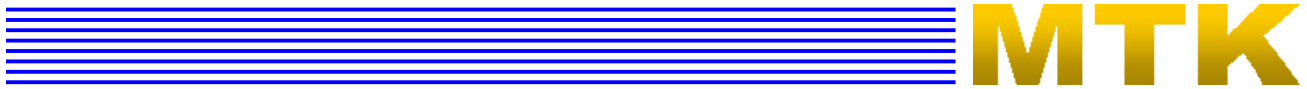

MT8205/8203

Specifications are subject to change without notice

Application Notes

MT8205/8203 Application Notes

MT8205/8203 is a highly integrated single chip for LCD TV supporting video input and output format up to HDTV. It includes 3D comb filter TV Decoder to retrieve the best image from popular composite signals. On-chip advanced motion adaptive de-interlacer converts accordingly the interlace video into progressive one with overlay of a 2D Graphic processor. Optional 2nd HDTV or SDTV inputs allows user to see multi-programs on same screen. Flexible scalar provides wide adoption to various LCD panel for different video sources. Its on-chip audio processor decodes analog signals from Tuner with lip sync control, delivering high quality post-processed sound effect to customers. On-chip microprocessor reduces the system BOM and shortens the schedule of UI design by high level C program. MT8205/8203 is a cost-effective and high performance HDTV-ready solution to TV manufactures.

FEATURES

■ Video Input

Input Multiplexing:

- Without external switch, it supports
- 1x Component,
- 1x S-video,
- 1x VGA/Component, (dual function ports)
- 1x Digital and
- 3x Composite inputs
- All the input sources can be flexibly routed to Main/PIP internally

Input Formats:

- Support VGA input up to SXGA ([1280x1024@60Hz](#)) including SOG VGA
- Support HDTV 480p/720p/1080i input
- Support DVI 24-bit RGB digital input
- Support CCIR-656/601 digital input

■ TV decoder

For PIP/POP:

- Dual identical TVD on chip (Single on MT8203)
- 3D-Comb for both path.
- Dual VBI decoders for the application of V-Chip

Supporting formats:

- Support PAL (B,G,D,H,M,N,I,Nc), PAL(Nc), PAL, NTSC, NTSC-4.43, SECAM
- Automatic Luma/Chroma gain control
- Automatic TV standard detection
- NTSC/PAL Motion Adaptive 3D comb filter
- Motion Adaptive 3D Noise Reduction
- VBI decoder for Closed-Caption/XDS/ Teletext/WSS/VPS
- Macrovision detection

■ 2D-Graphic/OSD processor

- Two OSD planes. (For example, Teletext and V-Chip will occupy one planes)
- Support alpha blending among these two planes and video
- Support Text/Bitmap decoder
- Support line/rectangle/gradient fill
- Support bitblt
- Support color Key function
- Support Clip Mask
- 65535/256/16/4/2-color bitmap format OSD,
- Automatic vertical scrolling of OSD image
- Support OSD mirror and upside down

■ Host Micro controller

- Turbo 8032 micro controller
- Built-in internal 373 and 8-bit programmable lower address port
- 2048-bytes on-chip RAM
- Up to 4M bytes FLASH-programming interface
- Supports 5/3.3-Volt. FLASH interface
- Supports power-down mode
- Supports additional serial interface
- IR control serial input
- Support RS232 interface
- Support single interface directly supporting SD/MS/MMC memory card
- Support 2 PWM output
- Support DDC2Bi/DDC2B/DDC1/DDCCI
- Maximum 48 programmable GPIO pins
- DRAM Controller
- Supports up to 32M-byte SDR/DDR DRAM
- Supports 16 bit DDR or 32 bit SDR/DDR bus interface
- Build in a DRAM interface programmable clock to optimize the DRAM performance
- Programmable DRAM access cycle and refresh cycle timings
- Maximum DRAM clock rate is 166MHz
- Support 3.3/2.5-Volt SDR/DDR Interface

■ Video Processor

Color Management

- Flesh tone and multiple-color enhancement. (For skin, sky, and grass...)
- Gamma/anti-Gamma correction
- Color Transient Improvement (CTI)
- Saturation/hue adjustment

Contrast/Brightness/Sharpness Management

- Sharpness and DLTI/DCTI
- Brightness and contrast adjustment
- Black level extender
- White peak level limiter
- Adaptive Luma/Chroma management

De-interlacing

- Automatic detect film or video source



- 3:2/2:2 pull down source detection
- Advanced Motion adaptive de-interlacing

Scaling

- Arbitrary ratio vertical/horizontal scaling of video, from 1/32X to 32X
- Advanced linear and non-linear Panorama scaling.
- Programmable Zoom viewer
- Picture-in-Picture (PIP)
- Picture-Out-Picture (POP)

Display

- 12/10, 10/8, 8/6 Dithering processing for LCD display
- 10bit gamma correction
- Support Alpha blending for Video and two OSD planes
- Frame rate conversion

■ Audio Input/Output

- 2 path TV audio in.
- Support AF/SIF decode from Tuner.
- 2 channel audio L/R digital line in.
- Total support 12 channel digital outputs optional for general stereo, 2.1 channel with subwoofer, 5.1 channel, and headphone out.

■ Audio Features

- Support BTSC/EIAJ/A2/NICAM decode
- Stereo demodulation, SAP demodulation
- Mode selection (Main/SAP/Stereo)
- Equalizer
- Sub-woofer/Bass enhancement
- MTK proprietary 3D surround processing (Virtual surround)
- Audio and video lip synchronization
- Support Reverberation

■ JPEG Decoder

- Decode base-line/progressive JPEG file thru memory card i/f
- SD/MS/MMC, Maximum 1000 files (depend on DRAM size), FW is not finished yet. (10/E will be ready)

■ Video Output

- 480i/576i/480p/576p/720p/1080i
- Up to ([1280x1024@75Hz](#)) (1366x768@60Hz)
- Dual-channel 6/8-bit LVDS/TTL output
- Support video output mirror and upside down

■ DRAM Usage

- For features of 8205, 2pcs of 8x16 DDR166 is necessary
- For features of 8203, 2/1pcs of 8x16 DDR (limited PIP/POP features)
- Here is a comparison chart between (2xDDR) and (1xDDR)



	DDR*1(16Mb)	DDR*2(32Mb)
NR	Y	Y
3D-Comb	Y	Y
MDDi	480i/576i	1080i
PIP	*Y	Y
POP	*Y	Y
Display	1024x768	1920x1080

- For 1080i input, 8203 only support bob mode de-interlacing.
- With single DDR, we could support very limited PIP/POP mode.

■ Flash Usage

- Flash is used to store FW code, fonts, bitmaps, big tables for VGA, Video, Gamma..
- In our demo system, we can support 2-4 languages within 1MB flash.
- For single country, we need around 20KB to store font data.
- For more bitmaps, we need more flash space to store them.
- 2Mbytes is recommended to build a general TV model.

■ Outline

- 388-pin BGA package
- 3.3/1.8-Volt. Dual operating voltages
- 0.18um UMC process

BLOCK DIAGRAM

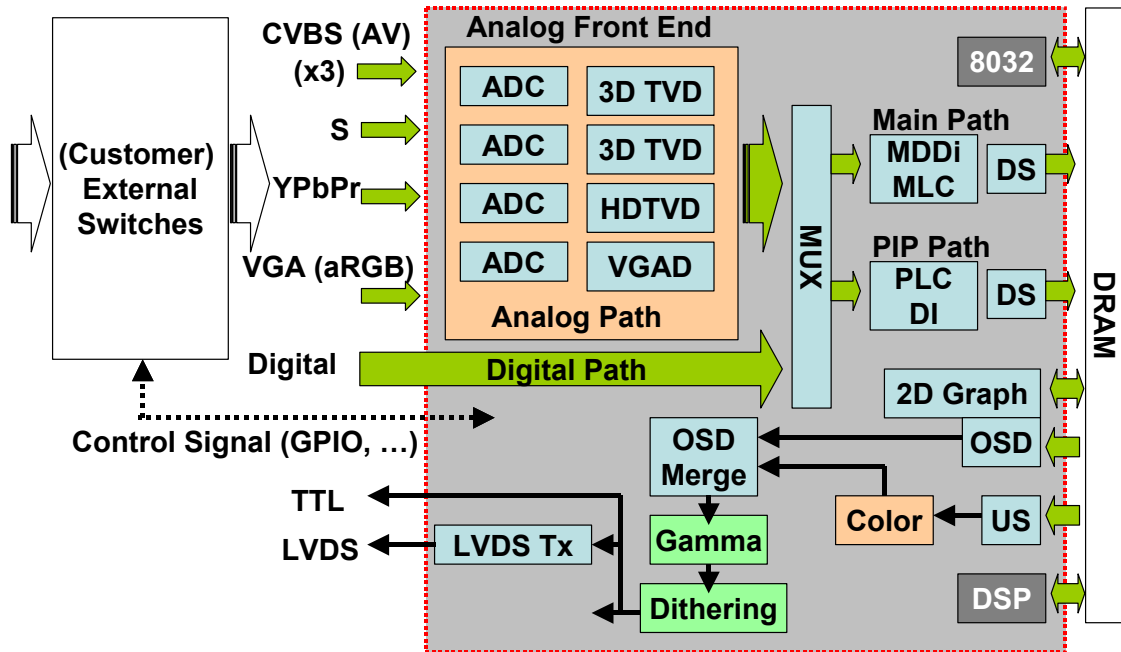

The Silicon Image logo features the words "Silicon Image" in a bold, italicized sans-serif font. A multi-colored arc (red, orange, yellow, green, blue) is positioned above the text, arching over the word "Image".

PanelLink[®]
Technology

SiI 169
HDCP PanelLink Receiver
Data Sheet

Document # SiI-DS-0049-B

Silicon Image, Inc.

SiI-DS-0049-B
August 2002

Application Information

To obtain the most updated Application Notes and other useful information for your design, contact your local Silicon Image sales office. Please also visit the Silicon Image web site at www.siliconimage.com.

Copyright Notice

This manual is copyrighted by Silicon Image, Inc. Do not reproduce, transform to any other format, or send/transmit any part of this documentation without the expressed written permission of Silicon Image, Inc.

Trademark Acknowledgment

Silicon Image, the Silicon Image logo, PanelLink[®] and the PanelLink[®] Digital logo are registered trademarks of Silicon Image, Inc. TMD5[™] is a trademark of Silicon Image, Inc. VESA[®] is a registered trademark of the Video Electronics Standards Association. All other trademarks are the property of their respective holders.

Disclaimer

This document provides technical information for the user. Silicon Image, Inc. reserves the right to modify the information in this document as necessary. The customer should make sure that they have the most recent data sheet version. Silicon Image, Inc. holds no responsibility for any errors that may appear in this document. Customers should take appropriate action to ensure their use of the products does not infringe upon any patents. Silicon Image, Inc. respects valid patent rights of third parties and does not infringe upon or assist others to infringe upon such rights.

Revision History

<u>Revision</u>	<u>Date</u>	<u>Comment</u>
A	07/18/2002	Release to Production with complete parametric information.
B	08/14/2002	Correction to DDC bus voltage level-shifting diagram; add Pb-free part number.

© 2002 Silicon Image, Inc.

TABLE OF CONTENTS

Functional Description	2
PanelLink TMDS Core	2
I ² C Interface and Registers	2
HDCP Decryption Engine and XOR Mask	3
HDCP Keys EEPROM.....	3
Panel Interface Logic and Configuration Logic	3
Electrical Specifications	4
Absolute Maximum Conditions.....	4
Normal Operating Conditions	4
DC Specifications	5
AC Specifications	6
Timing Diagrams	8
Input Timing.....	8
Output Timing	8
Pin Descriptions	11
Digital Output Pins.....	11
Configuration Pins	11
HDCP Pins	12
Power Management Pins	12
Differential Signal Data Pins.....	12
Reserved Pin.....	12
Power and Ground Pins	13
Feature Information	14
HSYNC De-jitter Function	14
Clock Detect Function	14
Sync Detect Function	14
OCK_INV Function.....	14
TFT Panel Data Mapping	16
Power Management	22
HDCP Operation	23
HDCP Authentication.....	23
SiI 169 HDCP Implementation	24
HDCP DDC / I ² C Interface.....	24
Video Requirement for I ² C Access	25
I ² C Registers.....	25
Using SiI 169 in SiI 161B Designs	28
EXT_RES Resistor Choice	29
Power Control.....	30
Receiver DDC Bus Level-Shifting	30
Voltage Ripple Regulation	31
Decoupling Capacitors	32
ESD Protection.....	32
Receiver Layout	33
EMI Considerations	33
PCB Thermal Design	33
Determining Heat Dissipation Requirements	33
Implementation Guidelines for Thermal Land Design	34
Board Mounting Guidelines	36
Stencil Design.....	37
Package.....	38
Ordering Information.....	38

LIST OF TABLES

Table 1. One Pixel per Clock Mode Data Mapping	16
Table 2. Two Pixel per Clock Mode Data Mapping	16
Table 3. One Pixel per Clock Input/Output TFT Mode – VESA P&D and FPDI-2™ Compliant.....	17
Table 4. Two Pixels/Clock Input/Output TFT Mode	18
Table 5. 24-bit One Pixel per Clock Input with 24-bit Two Pixel per Clock Output TFT Mode.....	19
Table 6. 18-bit One Pixel per Clock Input with 18-bit Two Pixel per Clock Output TFT Mode.....	20
Table 7. Two Pixel per Clock Input with One Pixel per Clock Output TFT Mode.....	21
Table 8. Power Management Functionality Table	22
Table 9. I ² C Register Mapping	26
Table 10. I ² C Register Definitions	27
Table 11. Link Impedance vs EXT_RES Value (all values in Ohms).....	29
Table 12. Power Consumption Characteristics	30
Table 13. Recommended Components	32

LIST OF FIGURES

Figure 1. SiI 169 Pin Diagram.....	1
Figure 2. Functional Block Diagram.....	2
Figure 3. Channel-to-Channel Skew Timing.....	8
Figure 4. Digital Output Transition Times	8
Figure 5. Receiver Clock Cycle/High/Low Times.....	8
Figure 6. Output Signals Setup/Hold Times.....	9
Figure 7. Output Signals Disabled Timing from PD# Active	9
Figure 8. Output Signals Disabled Timing from Input Clock Inactive.....	9
Figure 9. Input Clock Active to Output Active	9
Figure 10. SCDT Timing from DE Inactive/Active.....	10
Figure 11. TFT Two Pixels per Clock Staggered Output Timing Diagram.....	10
Figure 12. I ² C Data Valid Delay (driving Read Cycle data).....	10
Figure 13. Block Diagram for OCK_INV	15
Figure 14. HDCP System Architecture	23
Figure 15. I ² C Byte Read	24
Figure 16. I ² C Byte Write	24
Figure 17. Short Read Sequence	25
Figure 18. Design Using SiI 161B or SiI 169	29
Figure 19. DDC Bus Voltage Level-Shifting using Fairchild NDC7002N	30
Figure 20. Voltage Regulation using Texas Instruments TL431	31
Figure 21. Voltage Regulation using National Semiconductor LM317.....	31
Figure 22. Decoupling and Bypass Schematic	32
Figure 23. Decoupling and Bypass Capacitor Placement	32
Figure 24. DVI to Receiver Routing - Top View	33
Figure 25. Bottom View of Thermally Enhanced 100-pin TQFP Package.....	34
Figure 26. TQFP Thermal Land Design on PCB	35
Figure 27. Thermal Pad Via Grid.....	36
Figure 28. Recommended Stencil Design	37
Figure 29. Package Diagram	38

General Description

The SiI 169 Receiver uses PanelLink Digital technology to support HDTV and high-resolution digital displays for DTV and PC applications. It features High-bandwidth Digital Content Protection (HDCP) for secure delivery of high-definition video in consumer electronics products.

The SiI 169 comes with integrated, pre-programmed HDCP keys, greatly simplifying manufacturing and providing the highest level of security. For improved ease of use, the SiI 169 has enhanced jitter tolerance and a low-power standby mode.

PanelLink Digital technology is the world’s leading DVI solution, providing a digital interface solution that is easy to implement and cost-effective. PanelLink further simplifies the display interface design by resolving many of the system level issues associated with high-speed mixed signal circuits.

Features

- Integrated 25-165MHz PanelLink core to support VGA to UXGA resolutions
- Supports HDTV resolutions (720p/1080i)
- Integrated HDCP decryption engine for viewing protected content
- Pre-programmed HDCP keys provide highest level of key security, simplify manufacturing
- Enhanced jitter tolerance
- Time staggered data output for reduced ground bounce
- High Skew Tolerance: 1 full input clock cycle (6ns at 165MHz)
- Backwards compatible with SiI 161B
- Sync Detect for “Hot Plugging”
- Flexible low power modes with automatic power down when input clock is inactive
- Low power 3.3V core operation
- Compliant with DVI 1.0
- Standard and Pb-free packages (see page 38).

SiI 169 Pin Diagram

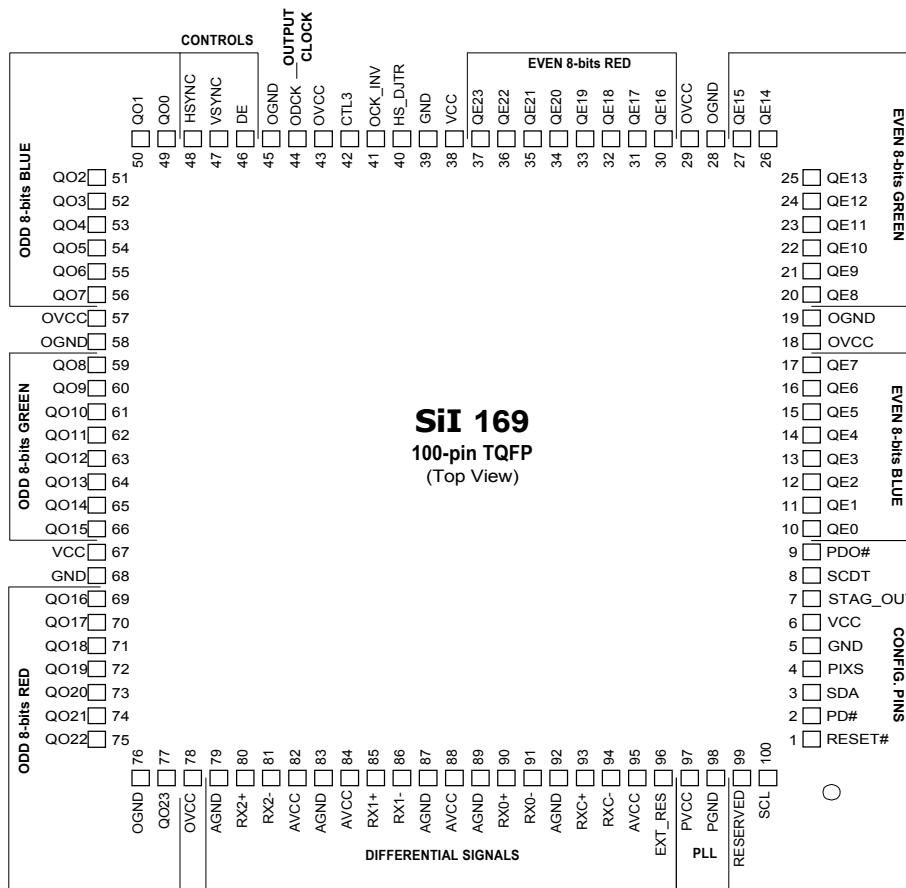

Figure 1. SiI 169 Pin Diagram

Functional Description

The SiI 169 is a DVI 1.0 compliant digital-output receiver with built-in High-bandwidth Digital Content Protection (HDCP). It provides a simple, cost effective solution for DTVs implementing DVI-HDCP. Pre-programmed HDCP keys simplify manufacturing while providing the highest level of security. There is no need to use encrypted keys, program EEPROMs, or cure epoxy coating.

Figure 2 shows the functional blocks of the chip.

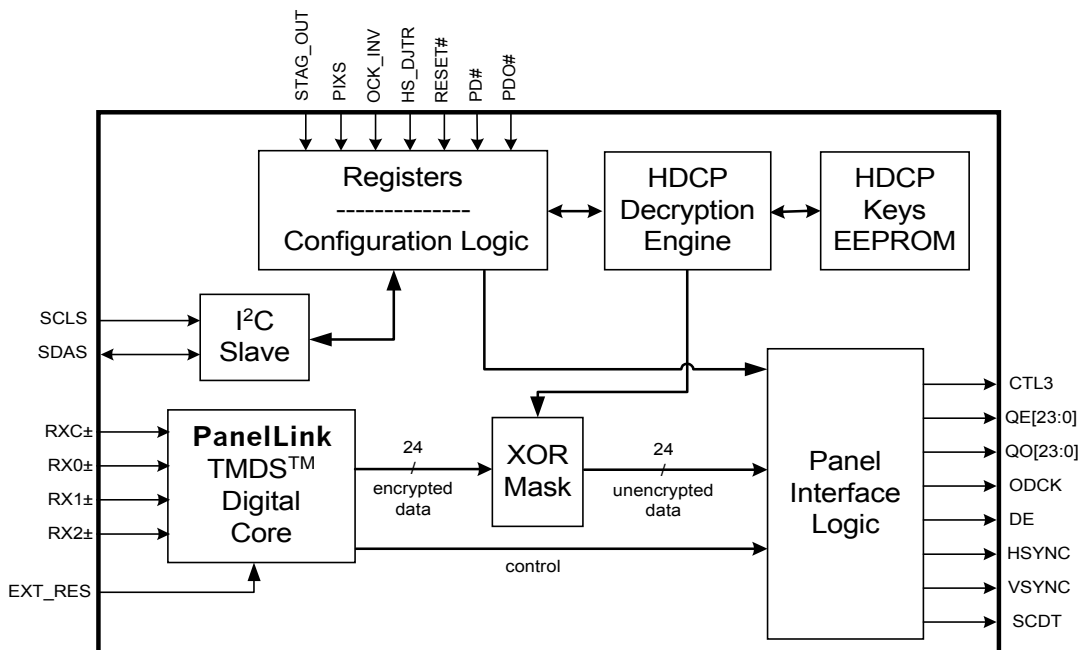

Figure 2. Functional Block Diagram

PanelLink TMDSTM Core

The PanelLink TMDSTM core accepts as inputs the three TMDSTM differential data lines and the differential clock. The core senses the signals on the link and properly decodes them providing accurate pixel data. The core outputs the necessary sync signals (HSYNC, VSYNC), clock (ODCK), and a display enable (DE) signal that drives high when video pixel data is present. The SCDT signal is output when there is active video on the DVI link and the PLL has locked on to the video. SCDT can be used to trigger external circuitry, indicating that an active video signal is present; or used to place the device outputs in power down when no signal is present (by tying SCDT to PDO#). A resistor tied to the EXT_RES pin is used for impedance matching.

I²C Interface and Registers

The SiI 169 uses a slave I²C interface, capable of running at 400kHz, for communication with the host. HDCP authentication is managed by reading and writing to registers through the I²C interface. This bus, called DDC in the DVI specification, is also tied to the EDID EEPROM that contains information about the display's capabilities (resolution, aspect ratio, etc.). The I²C address of the SiI 169 is 74h as specified by HDCP. This interface is not 5V tolerant and it is recommended that a voltage level shifter be used between the SiI 169 and the DVI connector as the DDC bus is specified to support 5V signaling.

HDCP Decryption Engine and XOR Mask

The HDCP decryption engine contains all the necessary logic to decrypt an incoming video signal on a pixel-by-pixel basis. The host system microcontroller initiates an authentication sequence with the receiver to initialize the SiI 169 HDCP decryption engine. Upon successful completion of the authentication process, the SiI 169 is ready to decrypt the incoming video via the XOR mask.

Encrypted and unencrypted video will be sent at different times. Therefore the host HDCP transmitter uses the CTL3 signal to indicate to the SiI 169 receiver whether the incoming video is encrypted or not.

HDCP Keys EEPROM

The SiI 169 comes pre-programmed with a production set of HDCP keys in its internal EEPROM. In this way the keys are provided the highest level of protection as required by the HDCP specification. Silicon Image manages all aspects of the key purchasing and programming. There is no need for the customer to purchase HDCP keys from the licensing authority. For security reasons, the keys cannot be read out of the device.

Samples of the SiI 169 are available with the B1 public keys as listed in the back of the HDCP specification. These are marked with a -PUB part number as noted in the Ordering Information section. Make sure to request either “Public” or “Production” keys when requesting samples. Before receiving samples of the SiI 169 with production keys a customer must have signed the HDCP license agreement.

Panel Interface Logic and Configuration Logic

Unencrypted video data is sent to the display logic by way of a 48-bit output interface. The functionality of this interface is affected by several of the externally strapped configuration logic options as follows.

- The data output can be presented in either one pixel per clock or two pixels per clock format, depending on the PIXS configuration setting.
- The polarity of the output clock ODCK can be inverted to accommodate both rising- and falling-edge clocking through the OCK_INV configuration setting.
- Using the STAG_OUT configuration setting, the odd and even data output groups can be staggered in time to reduce EMI.
- The HS_DJTR configuration setting can compensate for host-side jitter on the HSYNC input to the transmitter.
- The PD# and PDO# inputs select chip power down modes and allow for disabling of the outputs to the panel.

The RESET# input must be in the HIGH state during normal operation, in both HDCP and non-HDCP modes. Its primary purpose is to reset the digital block circuitries, including the HDCP engine, and registers at initial chip power-up time. The VSYNC, HSYNC, DE, and CTL3 signals will be driven low while RESET# is asserted. If it is necessary to disable the HDCP engine while leaving the chip fully operational for reception of unencrypted video, use the software reset feature located at bit 0 of register 0xFF by setting it to “1”.

Revision History**Revision 0.1 (15 Jan. 2002)**

- Original

Revision 0.2 (19 Nov. 2002)

-changed ordering information & DC/AC characteristics

Revision 0.1	Revision 0.2
M13S128168A - 5T	M13S128168A - 6T
M13S128168A - 6T	M13S128168A - 7.5AB

Revision 0.3 (8 Aug. 2003)

-Change IDD6 from 3mA to 5mA.

Revision 0.4 (27 Aug. 2003)

-Change ordering information & DC / AC characteristics.

Revision 1.0 (21 Oct. 2003)

-Modify tWTR from 2tck to 1tck.

Revision 1.1 (10 Nov. 2003)

-Correct some refresh interval that is not revised.

-Correct some CAS Latency that is not revised.

Revision 1.2 (12 Jan. 2004)

-Correct IDD1; IDD4R and IDD4W test condition.

-Correct tRCD; tRP unit

-Add tCCD spec.

-Add tDAL spec.

Revision 1.3 (12 Mar. 2004)

-Add Cas Latency=2; 2.5

DDR SDRAM**2M x 16 Bit x 4 Banks****Double Data Rate SDRAM****Features**

- JEDEC Standard
- Internal pipelined double-data-rate architecture, two data access per clock cycle
- Bi-directional data strobe (DQS)
- On-chip DLL
- Differential clock inputs (CLK and $\overline{\text{CLK}}$)
- DLL aligns DQ and DQS transition with CLK transition
- Quad bank operation
- CAS Latency : 2; 2.5; 3
- Burst Type : Sequential and Interleave
- Burst Length : 2, 4, 8
- All inputs except data & DM are sampled at the rising edge of the system clock(CLK)
- Data I/O transitions on both edges of data strobe (DQS)
- DQS is edge-aligned with data for reads; center-aligned with data for WRITE
- Data mask (DM) for write masking only
- $V_{DD} = 2.375V \sim 2.75V$, $V_{DDQ} = 2.375V \sim 2.75V$
- Auto & Self refresh
- 7.8us refresh interval
- SSTL-2 I/O interface
- 66pin TSOPII package

Operating Frequencies :

PRODUCT NO.	MAX FREQ	VDD	PACKAGE
M13S128168A -5T	200MHz	2.5V	TSOPII
M13S128168A -6T	166MHz		

Functional Block Diagram

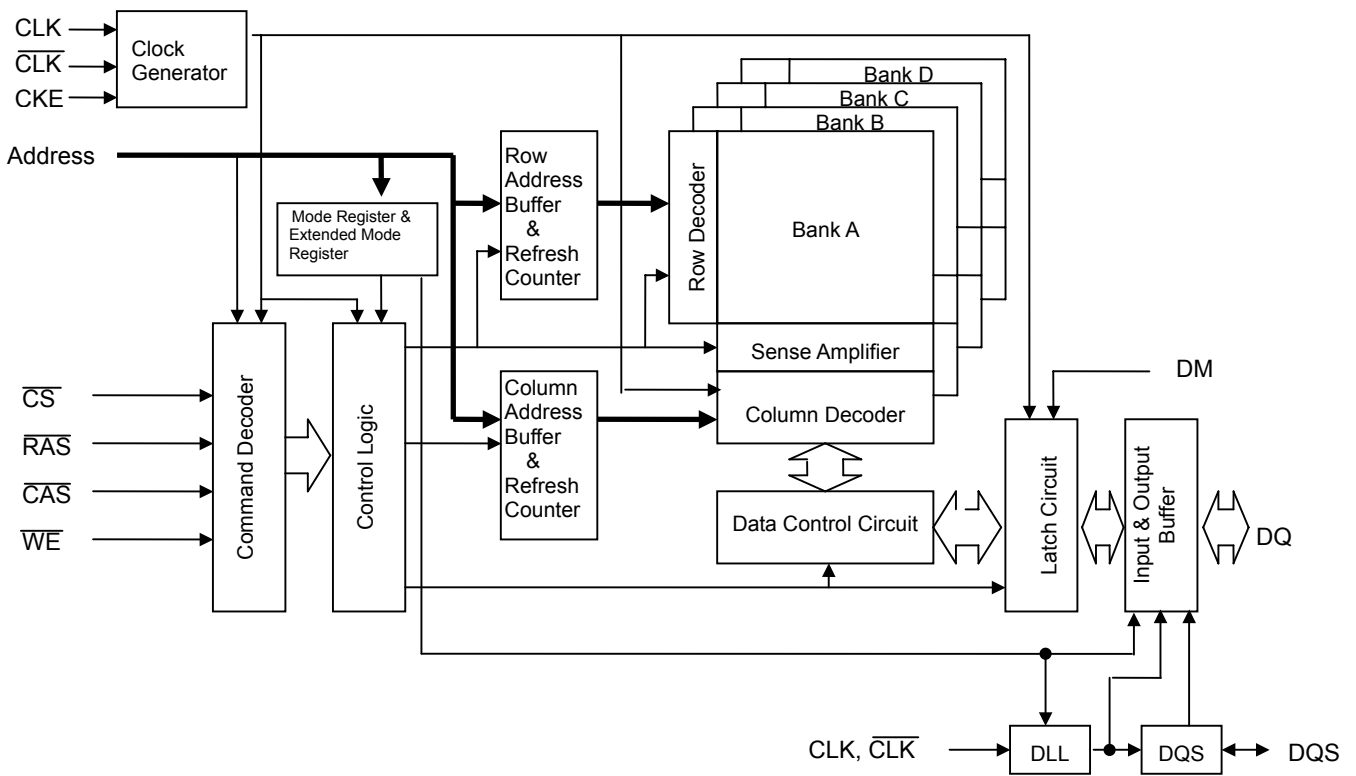

Pin Arrangement

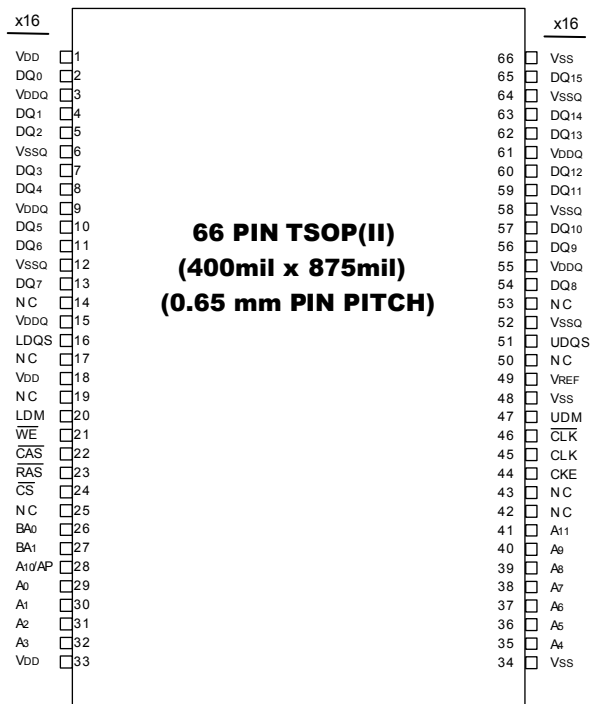

General Description

The MP7720 is a mono 20W Class-D Audio Amplifier. It is one of MPS' second generation of fully integrated audio amplifiers which dramatically reduces solution size by integrating the following:

- **180mΩ power MOSFETs**
- **Start up / shut down pop elimination**
- **Short circuit protection circuits**
- **Mute / Stand By**

The MP7720 utilizes a single ended output structure capable of delivering 20W into 4Ω speakers. MPS Class-D Audio Amplifiers exhibit the high fidelity of a Class A/B amplifier at efficiencies greater than 90%. The circuit is based on the MPS' proprietary variable frequency topology that delivers excellent PSRR, fast response time and operates on a single power supply.

Ordering Information

Part Number *	Package	Temperature
MP7720DS	SOIC8	-40°C to + 85°C
MP7720DP	PDIP8	-40°C to + 85°C
EV0030	Evaluation Board	

* For Tape & Reel use suffix - Z (e.g. MP7720DS-Z)

* For Lead Free use suffix - LF (e.g. MP7720DS-LF)

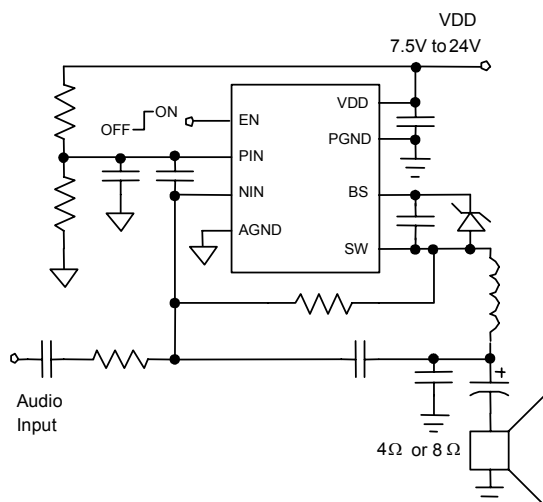

Figure 1: Typical Application Circuit

Features

- 20W output at $V_{DD}=24V$ into a 4Ω load
- THD+N = 0.04% @ 1W, 8Ω
- 93% efficiency at 20W
- Low noise (190μV typical)
- Switching Frequency to 1MHz
- 9.5V to 24V operation from single supply
- Integrated Start Up and Shut Down Pop Elimination Circuit
- Thermal protection
- Integrated 180mΩ switches
- Mute / Standby-mode (Sleep)
- Tiny 8 Pin SOIC or PDIP Package
- Evaluation Board Available

Applications

- Surround Sound DVD Systems
- Televisions
- Flat Panel Monitors
- Multimedia computers
- Home stereo

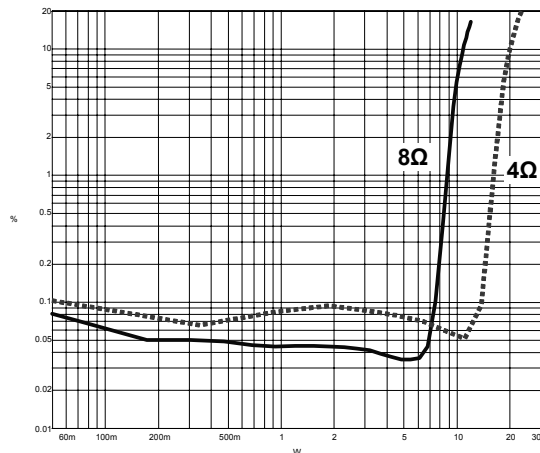

Figure 2: THD+N vs. Power (24V, 1KHz)

PRELIMINARY INFORMATION

Absolute Maximum Ratings		(Note 1)
Supply Voltage V_{DD}		26V
BS Voltage	$V_{SW}-0.3V$ to $V_{SW}+6.5V$	
Enable Voltage V_{EN}		-0.3V to 6V
V_{SW} , V_{PIN} , V_{NIN}		-1V to $V_{DD}+1V$
AGND to PGND		-0.3V to 0.3V
Junction Temperature		150°C
Lead Temperature		260°C
Storage Temperature		-65°C to 150°C

Recommended Operating Conditions		(Note 2)
Supply Voltage V_{DD}		9.5V to 24V
Operating Temperature T_A		-40°C to 85°C

Package Thermal Characteristics	
Thermal Resistance θ_{JA} (SOIC8)	105°C/W
Thermal Resistance θ_{JC} (SOIC8)	50°C/W
Thermal Resistance θ_{JA} (PDIP8)	95°C/W
Thermal Resistance θ_{JC} (PDIP8)	55°C/W

Table 1: Electrical Characteristics ($V_{DD}=24V$, $V_{EN}=5V$, $T_A=25^\circ C$)

Parameters	Condition		Typ	Max	Units
Supply Current					
Standby Current	$V_{EN} = 0V$		1	5	μA
Quiescent Current			1.5	3.0	mA
Output Drivers					
SW On Resistance	Sourcing and Sinking		0.18		Ω
Short Circuit Current	Sourcing and Sinking		5.0		A
Inputs					
PIN, NIN Input Common Mode Voltage Range		0	$\frac{V_{DD}}{2}$	$V_{DD}-1.5$	V
PIN, NIN Input Current	$V_{PIN}=V_{NIN}=12V$		1	5	μA
EN Enable Threshold Voltage	V_{EN} Rising		1.4	2.0	V
	V_{EN} Falling	0.4	1.2		V
EN Enable Input Current	$V_{EN} = 5V$		1		μA
Thermal Shutdown					
Thermal Shutdown Trip Point	T_J Rising		150		$^\circ C$
Thermal Shutdown Hysteresis			30		$^\circ C$

Table 2: Operating Specifications (Circuit of Figure 3, $V_{DD}=24V$, $V_{EN}=5V$, $T_A=25^\circ C$)

Standby Current	$V_{EN} = 0V$		130		μA
Quiescent Current			13		mA
Power Output	$f=1KHz$, THD+N = 10% , 4 Ω Load		20		W
	$f=1KHz$, THD+N = 10% , 8 Ω Load		10		W
THD+ Noise	$P_{OUT}=1W$, $f=1KHz$, 4 Ω Load		0.08		%
	$P_{OUT}=1W$, $f=1KHz$, 8 Ω Load		0.04		%
Efficiency	$f = 1KHz$, $P_{OUT}=1W$, 4 Ω Load		90		%
	$f = 1KHz$, $P_{OUT}=1W$, 8 Ω Load		95		%
Maximum Power Bandwidth			20		KHz
Dynamic Range			93		dB
Noise Floor	A-Weighted		190		μV
Power Supply Rejection	$f=1KHz$		60		dB

Note 1. Exceeding these ratings may damage the device.

Note 2. The device is not guaranteed to function outside its operating rating.

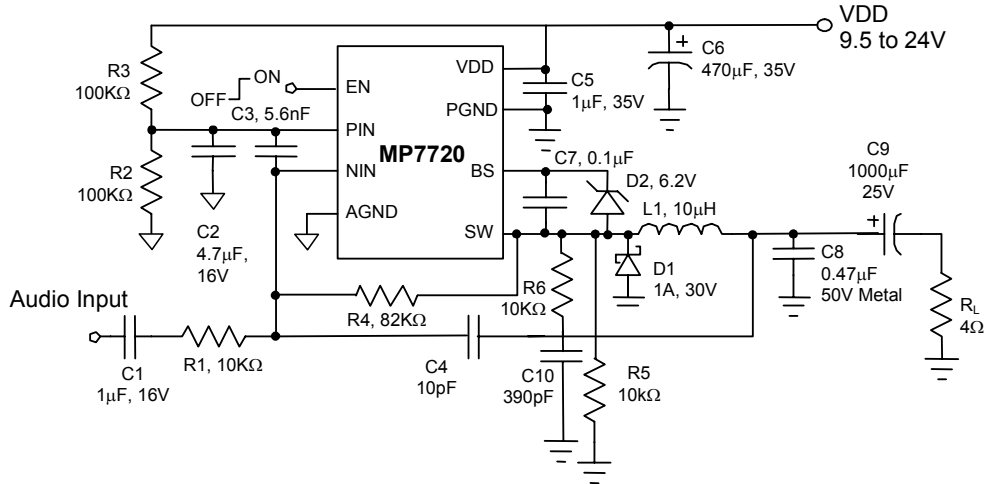

Figure 3: 20W Mono Typical Application Circuit

0. Warnings and Cautions

- ✓ WARNING indicates hazards that may lead to death or injury if ignored.
- ✓ CAUTION indicates hazards that may lead to injury or damage to property if ignored.



- 1) This product uses a high voltage (450 V max.). Do not touch the circuitry of this product with your hands when power is supplied to the product or immediately after turning off the power. Be sure to confirm that the voltage is dropped to a sufficiently low level.
- 2) Do not supply a voltage higher than that specified to this product. This may damage the product and may cause a fire.
- 3) Do not use this product in locations where the humidity is extremely high, where it may be splashed with water, or where flammable materials surround it. Do not install or use the product in a location that does not satisfy the specified environmental conditions. This may damage the product and may cause a fire.
- 4) If a foreign substance (such as water, metal, or liquid) gets inside the product, immediately turn off the power. Continuing to use the products it may cause fire or electric shock.
- 5) If the product emits smoke, an abnormal smell, or makes an abnormal sound, immediately turn off the power. If noting is displayed or if the display goes out during use, immediately turn off the power. Continuing to use the product as it is may cause fire or electric shock.
- 6) Do not disconnect or connect the connector while power to the product is on. It takes some time for the voltage to drop to a sufficiently low level after the power has been turned off. Confirm that the voltage has dropped to a safe level before disconnecting or connecting the connector. Otherwise, this may cause fire, electric shock, or malfunction.
- 7) Do not pull out or insert the power cable from/to an outlet with wet hands. It may cause electric shock.
- 8) Do not damage or modify the power cable. It may cause fire or electric shock.
- 9) If the power cable is damaged, or if the connector is loose, do not use the product; otherwise, this can lead to fire or electric shock.
- 10) If the power connector or the connector of the power cable becomes dirty or dusty, wipe it with a dry cloth. Otherwise, this can lead to fire.

Product Specification of PDP Module

USE

- 1) Because this product uses a high voltage, connecting or disconnecting the connectors while power is supplied to the product may cause malfunctioning. Never connect or disconnect the connectors while the power is on. Immediately after power has been turned off, a residual voltage remains in the product. Be sure to confirm that the voltage has dropped to a sufficiently low level.
- 2) Watching the display for a long time can tire the eyes. Take a break at appropriate intervals.
- 3) PDP's brightness and contrast ratio is lower than that of the CRT. The picture is dimmer with surrounding light and better for viewing in dark condition.
- 4) Do not cover or wrap the product with a cloth or other covering while power is supplied to the product.
- 5) Before turning on power to the product, check the wiring of the product and confirm that the supply voltage is within the rated voltage range. If the wiring is wrong or if a voltage outside the rated range is applied, the product may malfunction or be damaged.
- 6) Do not store this product in a location where temperature and humidity are high. This may cause the product to malfunction. Because this product uses a discharge phenomenon, it may take time to light (operation may be delayed) when the product is used after it has been stored for a long time. In this case, it is recommended to light all cells for about 2hours (aging).
- 7) If the glass surface of the display becomes dirty, wipe it with a soft cloth moistened with a neutral detergent. Do not use acidic or alkaline liquids, or organic solvents.
- 8) Do not tilt or turn upside down while the module package is carried, the product may be damaged.
- 9) This product is made from various materials such as glass, metal, and plastic. When discarding it, be sure to contact a professional waste disposal operator.

Repair and Maintenance

Because this product combines the display panel and driver circuits in a single module, it cannot be repaired or maintained at user's office or plant. Arrangements for maintenance and repair will be determined later

1. GENERAL DESCRIPTION

□ DESCRIPTION

The PDP42V6##### is a 42-inch 16:9 color plasma display module with resolution of 852(H) × 480(V) pixels. This is the display device which offers vivid colors with adopting AC plasma technology by LG Electronics Inc.

□ FEATURES

High peak brightness (1000cd/m² Typical) and high contrast ratio (3000:1 Typical) enables user to create high performance PDP SETs.

□ APPLICATIONS

- ✓ Public information display
- ✓ Video conference systems
- ✓ Education and training systems



Product Specification of PDP Module

□ ELECTRICAL INTERFACE OF PLASMA DISPLAY

The PDP42V6##### requires only 8bits of digital video signals for each RGB color.

In addition to the video signals, six different DC voltages are required to operate the display.

The PDP42V6##### is equipped with P-CUBE function which analyzes display signals to optimize system control factor for showing the best display performance.

□ GENERAL SPECIFICATIONS

- ✓ Model Name : PDP42V6##### (42V6##### Model)
- ✓ Number of Pixels : 852(H) × 480(V) (1pixel=3 RGB cells)
- ✓ Pixel Pitch : 1080 μ m (H) × 1080 μ m (V)
- ✓ Cell Pitch : 367 μ m (H) × 1080 μ m (V) (Green Cell basis)
- ✓ Display Area : 920.1(H) × 518.4(V) ±0.5mm
- ✓ Outline Dimension : 1005(H) × 597(V) × 61(D)±1mm
- ✓ Pixel Type : RGB Closed type
- ✓ Number of Gradations : (R)256 × (G)256 × (B)256 (16.7 Mega colors)
- ✓ Weight : 14.8 Kg ± 0.5 Kg (Net 1EA)
111 Kg ± 5 Kg (5EA/1BOX)
- ✓ Aspect Ratio : 16:9
- ✓ Peak Brightness : Typical 1000cd/m² (1/25 White Window)
- ✓ Contrast Ratio : Average 60:1 (In a bright room with 150Lux at center)
: Typical 3000:1 (In a dark room 1/25 White Window pattern at center)
- ✓ Power Consumption : Typical 220 W (Full White)
- ✓ Life-time : more than 60,000 Hours of continuous operation

Life-time is defined as the time when the brightness level becomes half of its initial value.

✓ Display Dot Diagram

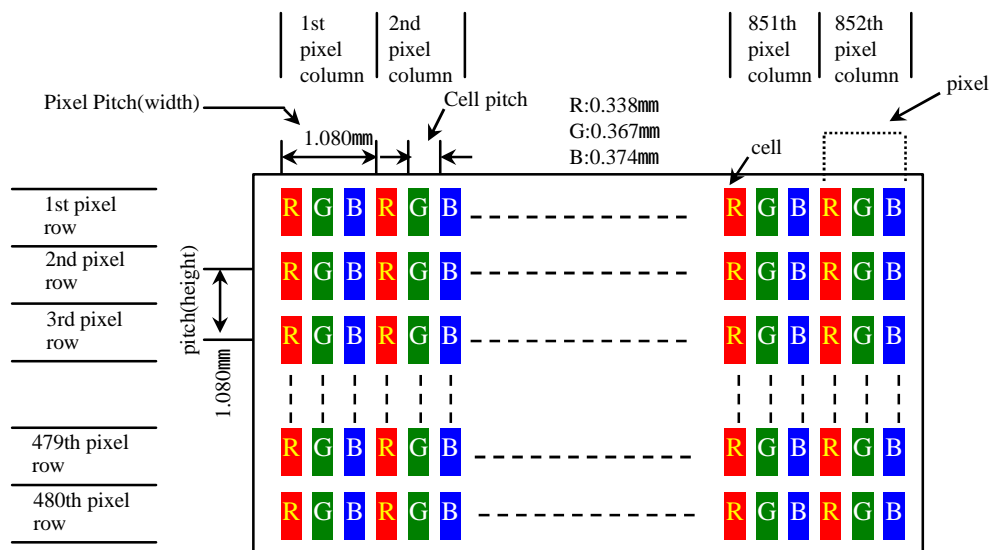

7. CONNECTORS and CONNECTIONS

❑ Power Input Connector

➤ Connector P3001 Pin Assignment

Pin No.	Symbol	Pin No.	Symbol
1	Vs	5	GND
2	Vs	6	Va
3	nc	7	GND
4	GND	8	+5V

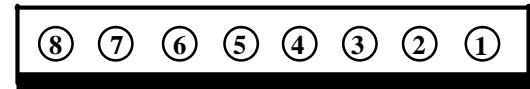

1-1123723-8 Pin numbers
(Top View, viewed from the pin connection side)

- ✓ Module side connector : 1-1123723-8 (Header)
- ✓ Mating Connector : 1-1123722-8 (Housing)
- ✓ Connector Supplier : AMP

➤ Connector P2005 Pin Assignment

Pin No.	Symbol	Pin No.	Symbol
1	VS	6	GND
2	VS	7	GND
3	VS	8	GND
4	nc	9	nc
5	GND	10	nc

- ✓ Module side connector : 1-1123723-10 (Header)
- ✓ Mating Connector : 1-1123722-10 (Housing)
- ✓ Connector Supplier : AMP

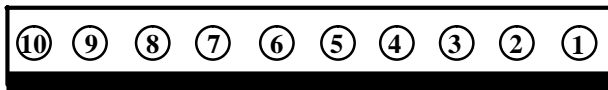

1-1123723-10 Pin numbers
(Top View, viewed from the pin connection side)

➤ Connector P2006 Pin Assignment

Pin No.	Symbol	Pin No.	Symbol
1	GND	3	5V
2	GND	4	5V

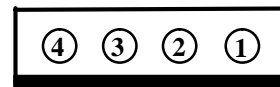

1-1123723-4 Pin numbers
(Top View, viewed from the pin connection side)

- ✓ Module side connector : 1-1123723-4 (Header)
- ✓ Mating Connector : 1-1123722-4 (Housing)
- ✓ Connector Supplier : AMP

8. Input/Output pin assignment & specification

CN808

#1 ~ #4 : +5Vctrl
#5 ~ #8 : GND

CN805

#1 ~ #2 : 5Vctrl
#3 ~ #4 : GND

CN806

#1 : Va
#2 : Va
#3 : GND
#4 : GND
#5 : GND
#6 : GND
#7 : NC
#8 : Vs
#9 : Vs
#10 : Vs

CN807

#1 : Vs
#2 : Vs
#3 : NC
#4 : GND
#5 : GND
#6 : Va
#7 : GND
#8 : +5V

CN804

#1 : 9Vsc
#2 : 9Vsc
#3 : GND
#4 : 5Vsc
#5 : 5Vsc
#6 : 5Vsc
#7 : GND
#8 : GND
#9 : GND

CN803

#1 ~ #3 : 5Vsc
#4 ~ #6 : GND
#7, #8 : 12Vsc
#9, #10 : GND
#11, #12 : NC

CN809

#1 : 9Vsc
#2 : GND

CN802

#1 ~ #2 : 30V or 24V
#3 ~ #4 : GND

Selection S/W

24V 30V

CN801

#1 : ACD
#2 : RLY ON
#3 : 5Vst_by
#4 : GND
#5 : Vs ON
#6 : 5VD
#7 : NC

Location No.	Specification	Vendor
CN01	3-176976-2(Red)	AMP
CN02	3-176976-1(Natural)	AMP
CN03	3-176976-1(Natural)	AMP
CN801	171825-7	AMP
CN802	171825-4	AMP
CN803	1-171825-2	AMP
CN804	171825-9	AMP
CN805	1-1123723-4	AMP
CN806	1-1123723-0	AMP
CN807	1-1123723-8	AMP
CN808	171825-8	AMP
CN809	171825-2	AMP

*** PSU operation method S/W**

CN01

From inlet

CN02

Live
Neutral

CN03

Live
Neutral

Before connecting with S/W : After connecting with S/W

9. Adjustment detail

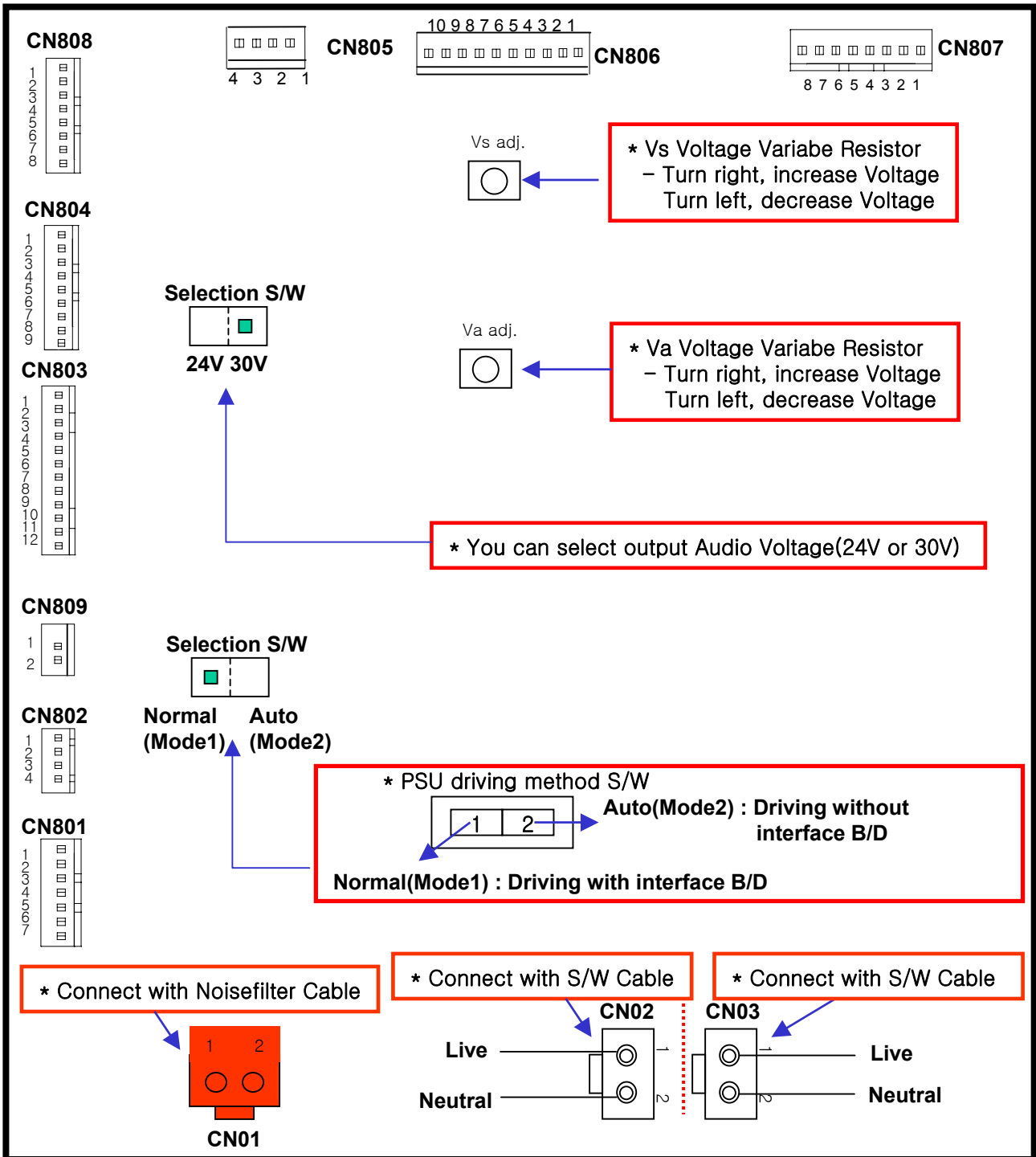

※ The color of CN01 is red.(The color of CN02, CN03 are natural.)

8. LABEL

□ LABEL Sticking Position

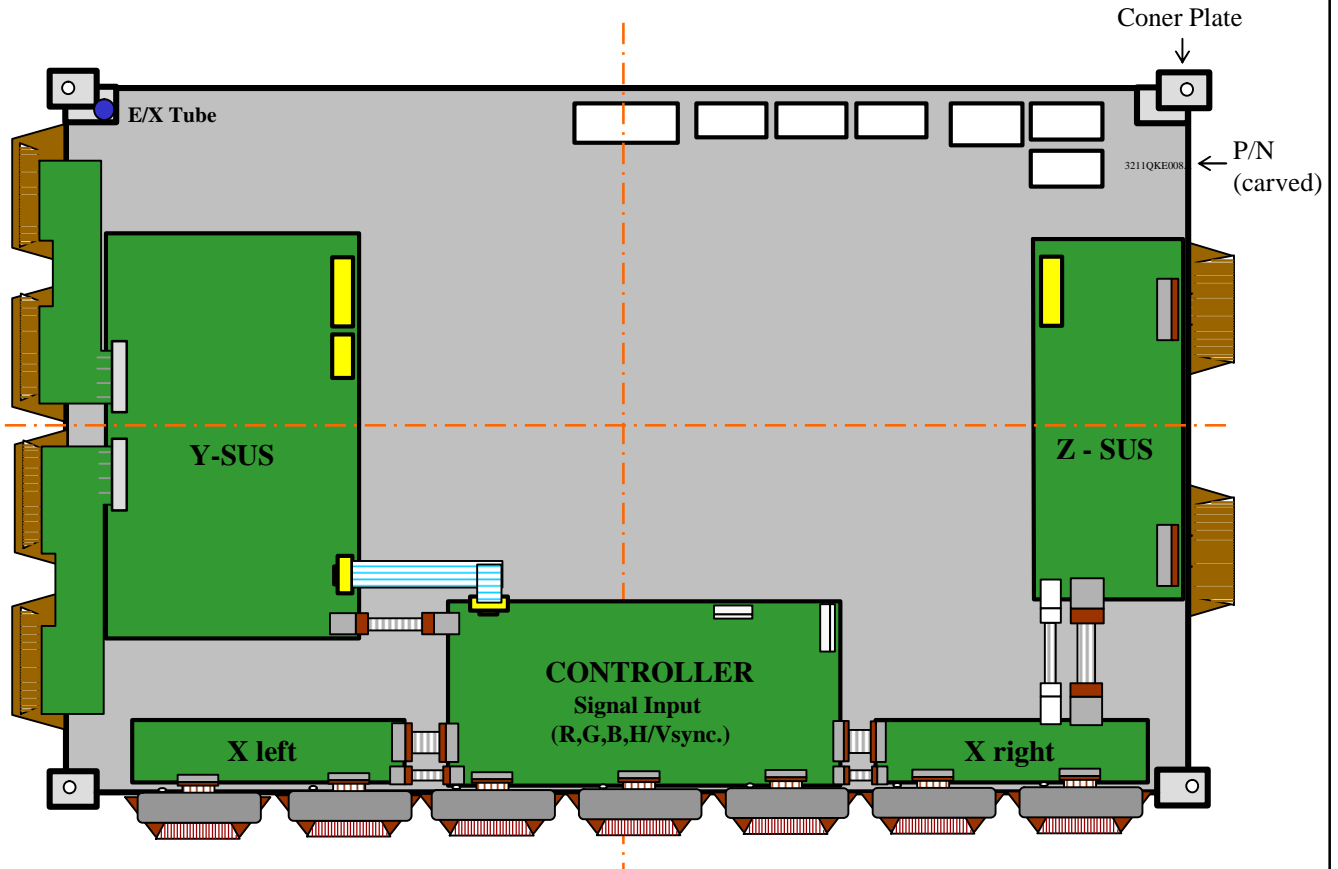

□ Identification Label : LABEL



- Model Name
- Bar Code (Code 128, Contains the manufacture No.)
- Manufacture No.
- The trade name of LG Electronics
- Manufactured date (Year & Month)
- Manufactured place

Trouble Shooting Manual of PDP Module

- Introduction**
- Precautions**
- Basic**
- Trouble shooting**

1. Introduction

COMPOSITION OF PDP BOARDS

● 42" V6 MODEL.

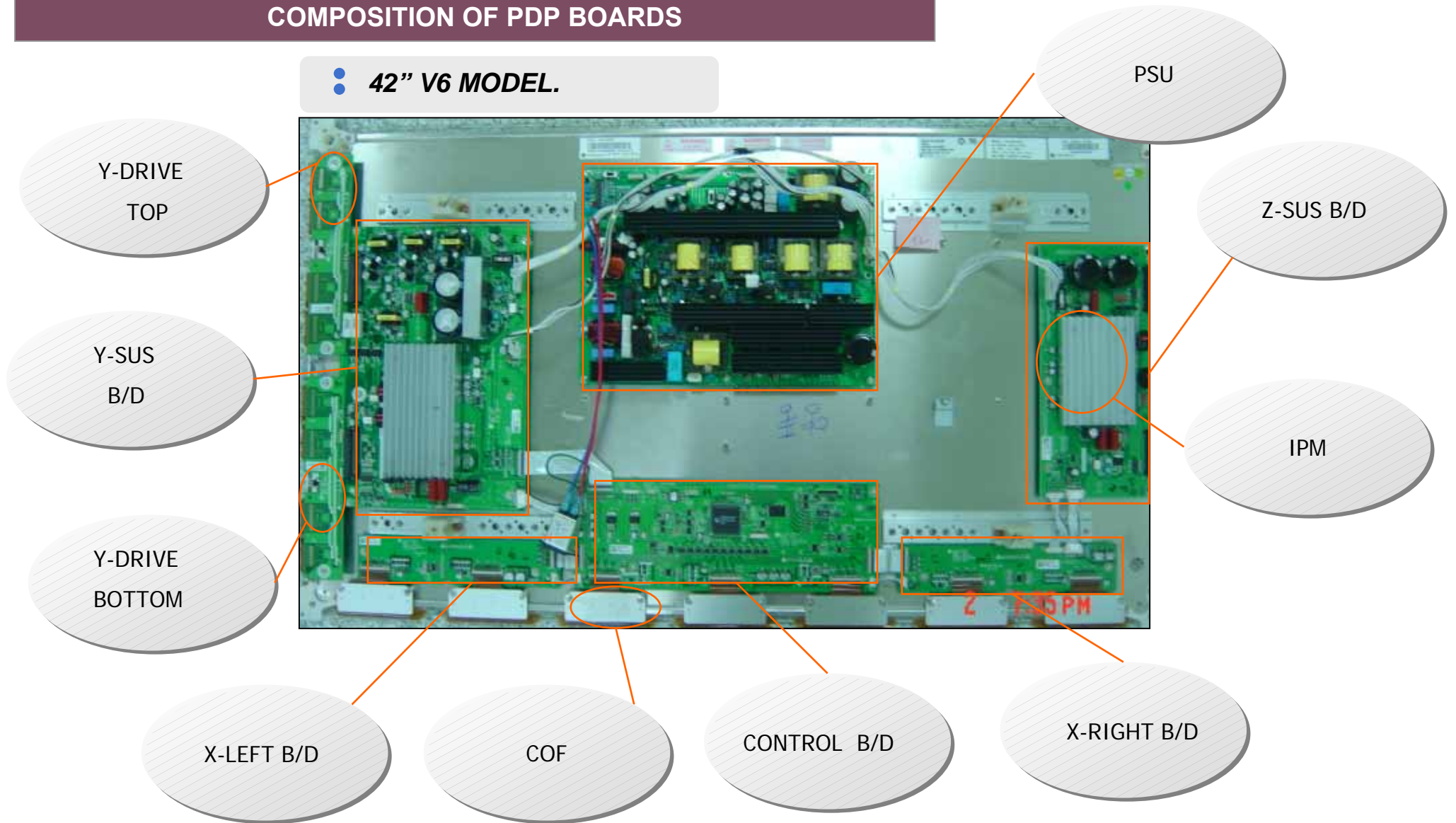

1. Introduction

• Definitions

Definition of MODULE position

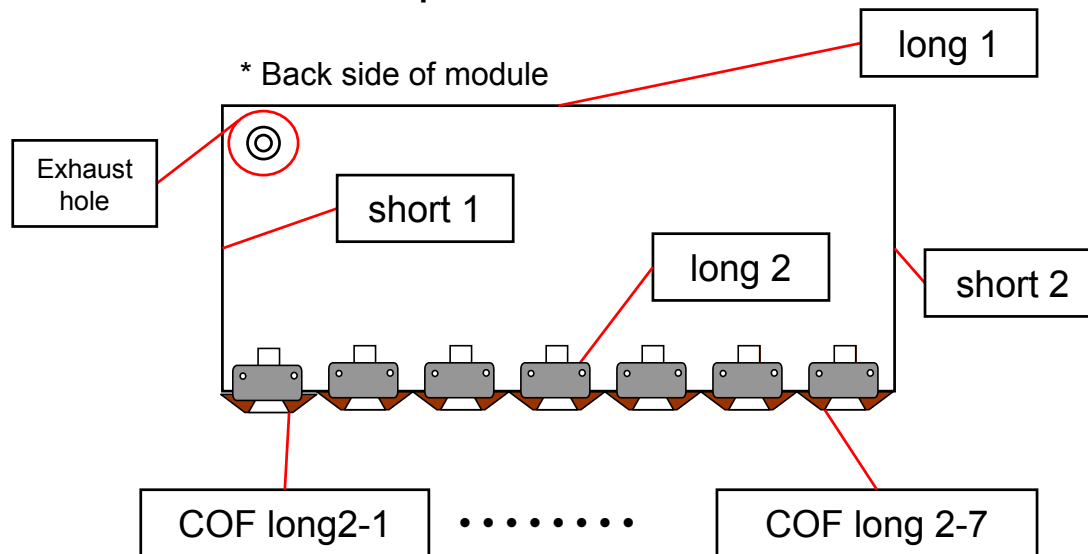

Identification label



- Model Name
- Bar Code (Code 128, Contains the manufacture No.)
- Manufacture No.
- The trade name of LG Electronics
- Manufactured date (Year & Month)
- The place Origin
- Model Suffix

1. Introduction

Voltage label (Attached on back side of module)

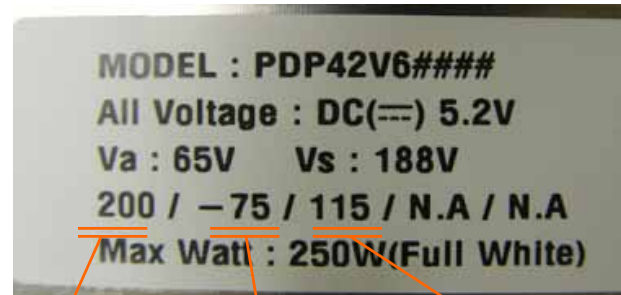

Vsetup

-Vy

Vsc

Part No. label (Attached on board)



PCB PART NO.

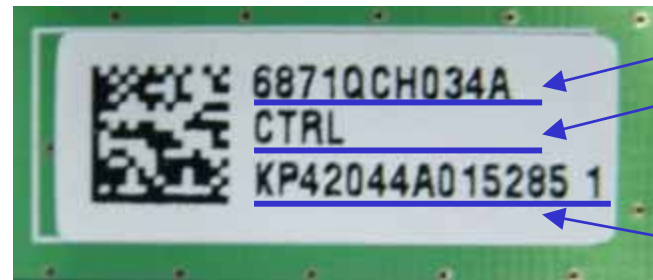

BOARD ASS'Y
PART NO.

BOARD NAME

BOARD SERIAL NO.



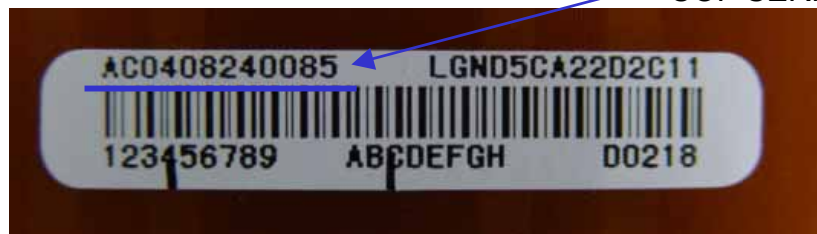

COF serial No. label (attached on COF)



COF SERIAL NO.

1. Introduction

Terms of defect

Term	Appearance
Add short (line on)	
Add open (line off)	
Sus short (line on)	
Sus open (line off)	

2. Precaution

• *Safety precautions*

Be sure to read this before service. When using/ handling this PDP module, Please pay attention to the below warning and cautions.

1. Before repairing there must be a preparation for 10 min.
2. Do not impress a voltage that higher than represented on the product.
3. Since PDP module uses high voltages, Be careful a electric shock and after removing power some current remains in drive circuit. so you can touch circuit after 1 min.
4. Drive circuits must be protected from static electricity.
5. The PDP module must be Moved by two man.
6. Be careful with short circuit of PDP boards when measuring any voltages.

• *Before request service*

1. Check panel surface and appearance of B/D.
 2. Check the model label. Whether it is boards of same model with label.
 3. Before requesting Service, please inform us a detail defect phenomenon and history of module. it can be helpful to us for a smooth sevice.
- Ex) COF long 2-1 fail ,address 1 line open, Y b/d problem , mis-discharge.

2. Precaution

- *Handle with care (COF)*

COF is the most important component in the PDP module.

Even a little imperfection of COF can make a serious screen problem.



SCRATCHING

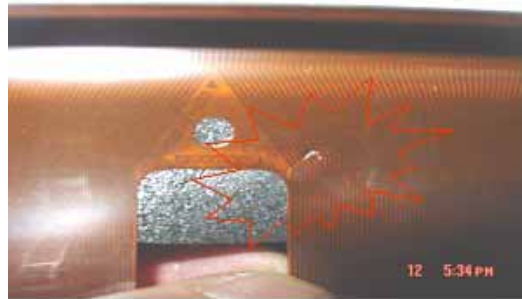

TEARING



BEING PUSHED

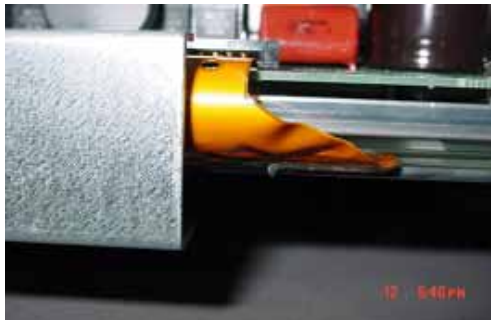

BENDING

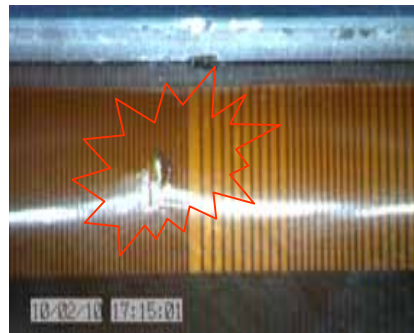

CHOPING

3. Basic

1. X B/D

: receiving LOGIC signal from CONTROL B/D and make ADDRESS PULSE(generates Address discharge)by ON/OFF operation, and supplies this waveform to COF(data)



X LEFT B/D

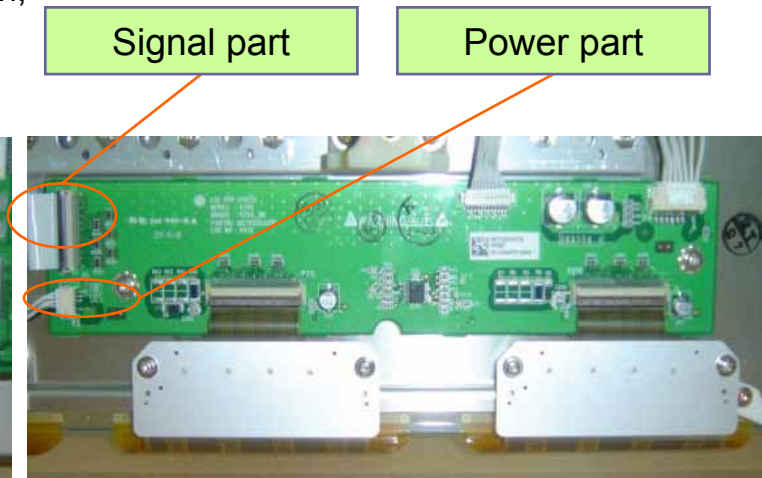

X RIGHT B/D

<COF Separating>

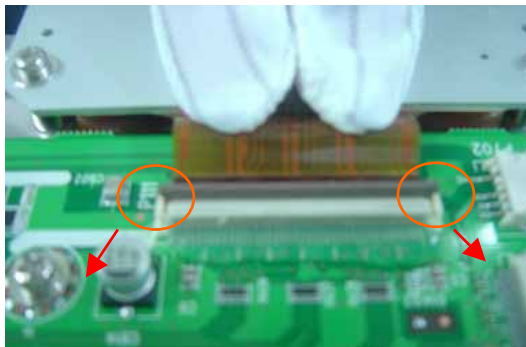

Lift up lock as shown in narrow.

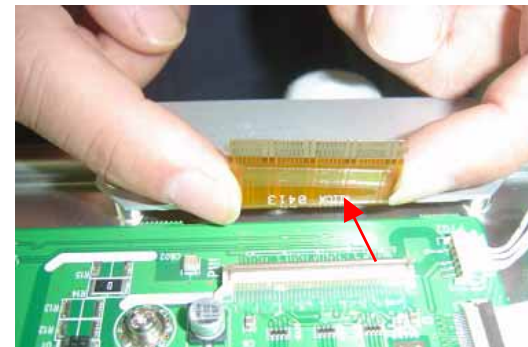

Pull COF as shown in narrow.

3. Basic

2. Z sustain B/D

: make SUSTAIN PULSE and ERASE PULSE that generates SUSTAIN discharge in panel by receiving LOGIC signal from CONTROL B/D.

this waveform is supplied to panel through FPC(Z).

*composed with IPM,FET,DIODE, electrolytic capacitor ,E/R coil.

* IPM (Intelligent Power Module)
E/R(Energy recovery)

<FPC Separating>



Separate the fixed Screw of Z-Board.
Pull out Lock as shown in arrow.

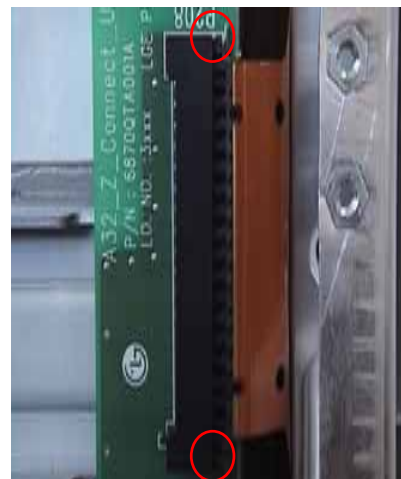

Condition in Lock part is pulled

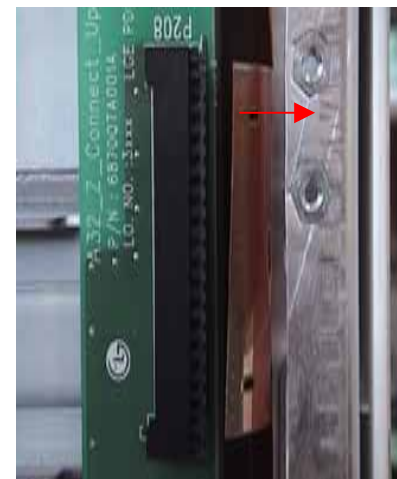

Pull FPC Connector
as shown in arrow.



3. Basic

3. Y drive B/D

- 1) This is a path to supply SUSTAIN ,RESET waveform which made from Y SUSTAIN B/D to panel through SCAN DRIVER IC.
- 2) Supply a wave form that select Horizontal electrode (Y SUSTAIN electrode) sequentially.
 - potential difference is 0V between GND and Vpp of DRIVER IC in SUSTAIN period.
 - being generated potential difference between GND and Vpp only in SCAN period.

* In case of 42" V6 use DRIVER IC IC 8 EA (TOP, BOTTOM: each 4EA)



3. Basic

4. Y sustain B/D

: generates SUSTAIN,RESET waveform, V_{sc} (SCAN)voltage.
and supplies it Y DRIVER B/D.

* Composed with IPM,DIODE, electrolytic capacitor ,FET.

5. Control Board

: creates signal processing (Contour noise,reduction ISM,..)
and an order of many FET on/off of each DRIVER B/D with
R,G,B each 8bit input.

* Use 3.3V/5V 2 kinds of power .



3. Basic

6. DC/DC Converter part

: Being impressed 5V, V_a , V_s ,

DC/DC converter makes

5V, V_a , V_s , V_{set_up} , V_{sc}

which is essential for each B/D.

There is no DC/DC B/D in

model 40" /42" (1 POWER B/D).

* 50" 60" embedded DC/DC B/D
separately because of high power
consumption.



3. Basic

7. FPC (Flexible Printed Circuit)

: supply a driving waveform to PANEL by connecting a PAD electrode of PANEL with PCB(Y and Z).

* there is two type of this for Y B/D. One is single-sided, another is double-side. These are having pattern on it

* for Z B/D, there is no pattern , single-sided, and Beta type(all of copper surface).



8. FFC (Flat Flexible Cable)

: for connecting a Logic signal between B/D and B/D.

*There is 0.5mm pitch,50pin type

1mm pitch ,30pin type.

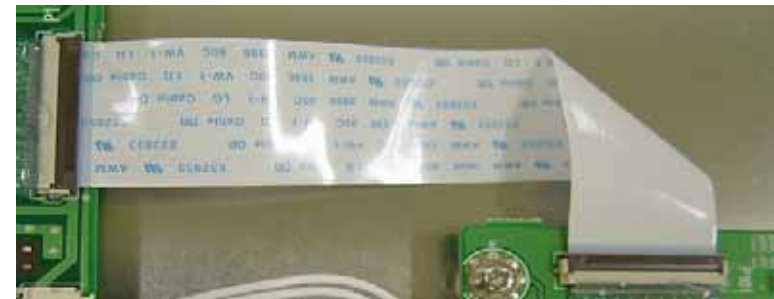

3. Basic

9. COF (Chip On Film)

: supply a waveform which made from X B/D to panel and select a output pin that is controlled by COF when be on or off.

96 output pin per IC.

the more the resolution higher, the less spare space where can set IC on it in B/D. without using IC PACKAGE, we can use a BARE IC , so we can get IC with LOW COST because we do not solder IC on PCB directly, a soldering defect rate decrease.

* composition

1) FPC + Heat /Sink

⇒ FPC for COF must have a Low Spec decline with getting damp

2) CHIP resistor + CHIP CAPACITOR

3) BARE IC (STV7610A/WAF) + GOLD WIRE/AL WIRE

4) EPOXY MOLDING

Bare IC

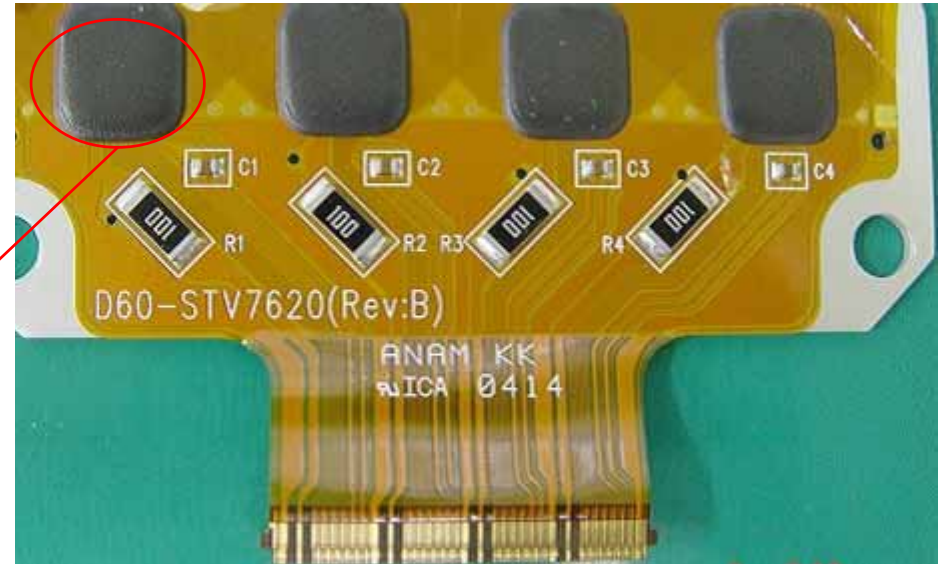

* 42 V6 COF is the same as 42V5.

3. Basic

10. IPM(Intelligent Power Module)

: composition

HEATSINK,CAPACITOR

DIODE

IC LINEAR

RESISTOR,TRANSISTOR,FETS.

: description

Attached at Z B/D and Y B/D, make Sustain waveform.

Sustainer : supply a square wave to panel to make a video.

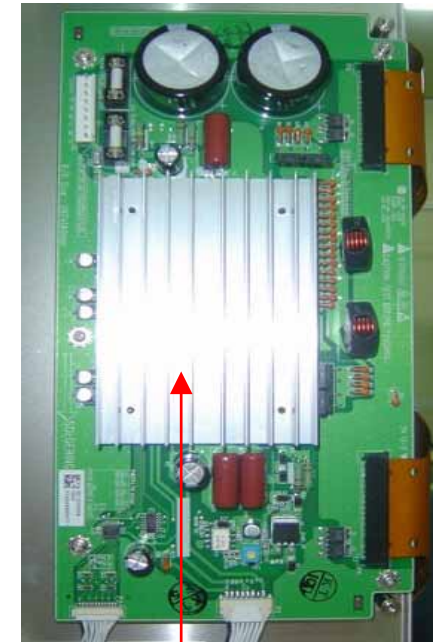
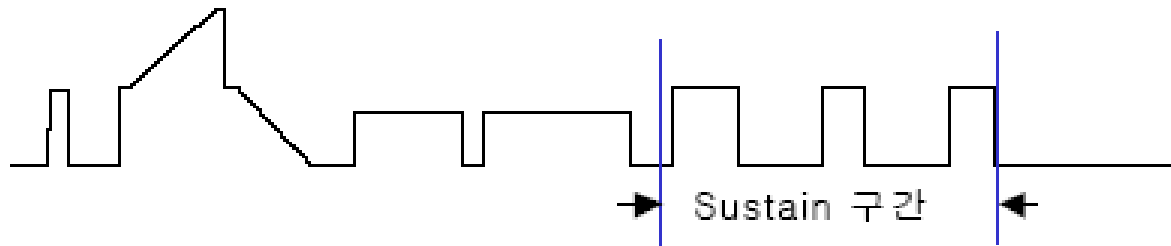

IPM

4. Trouble shooting.

• Fast check up

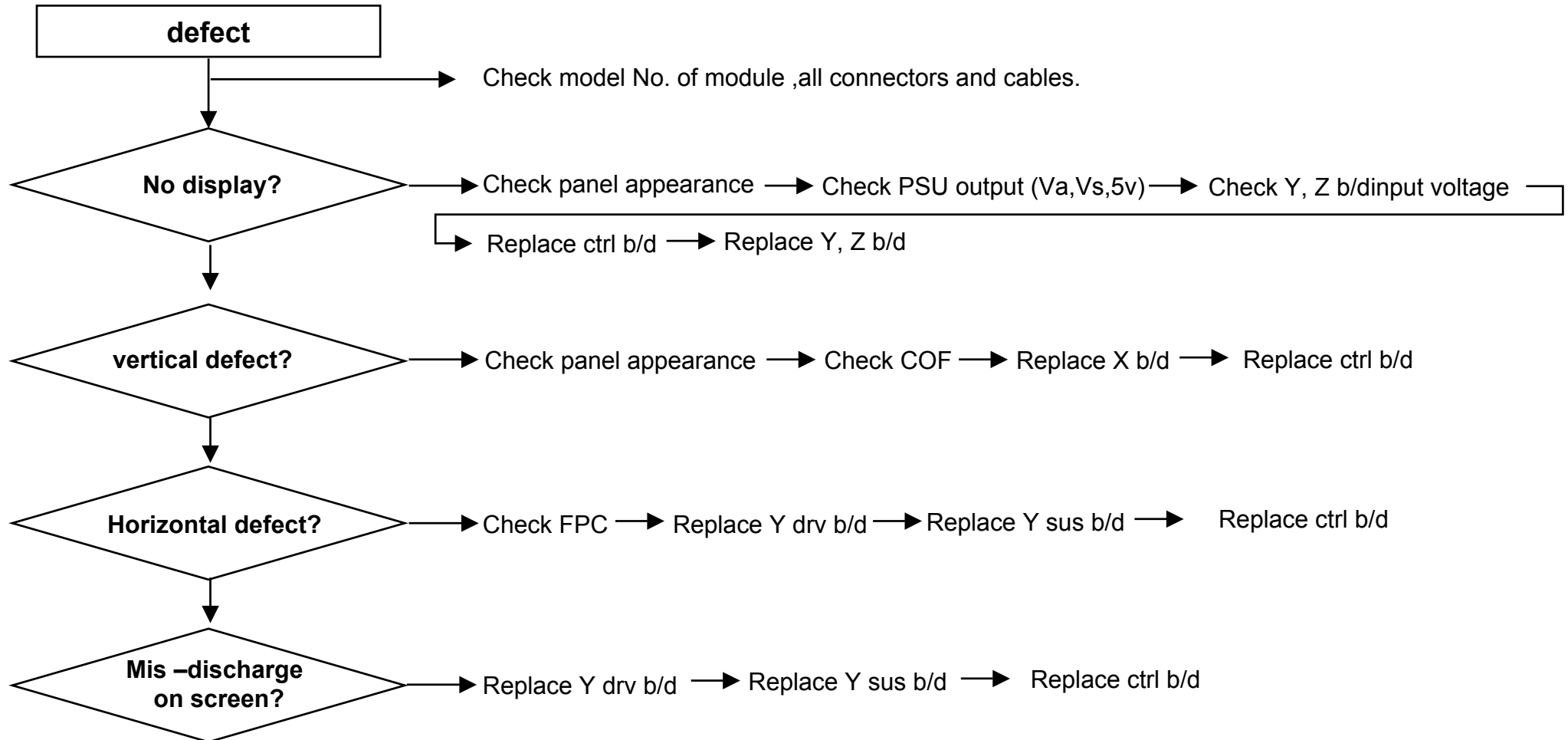

4. Trouble shooting.

• Logical judgment

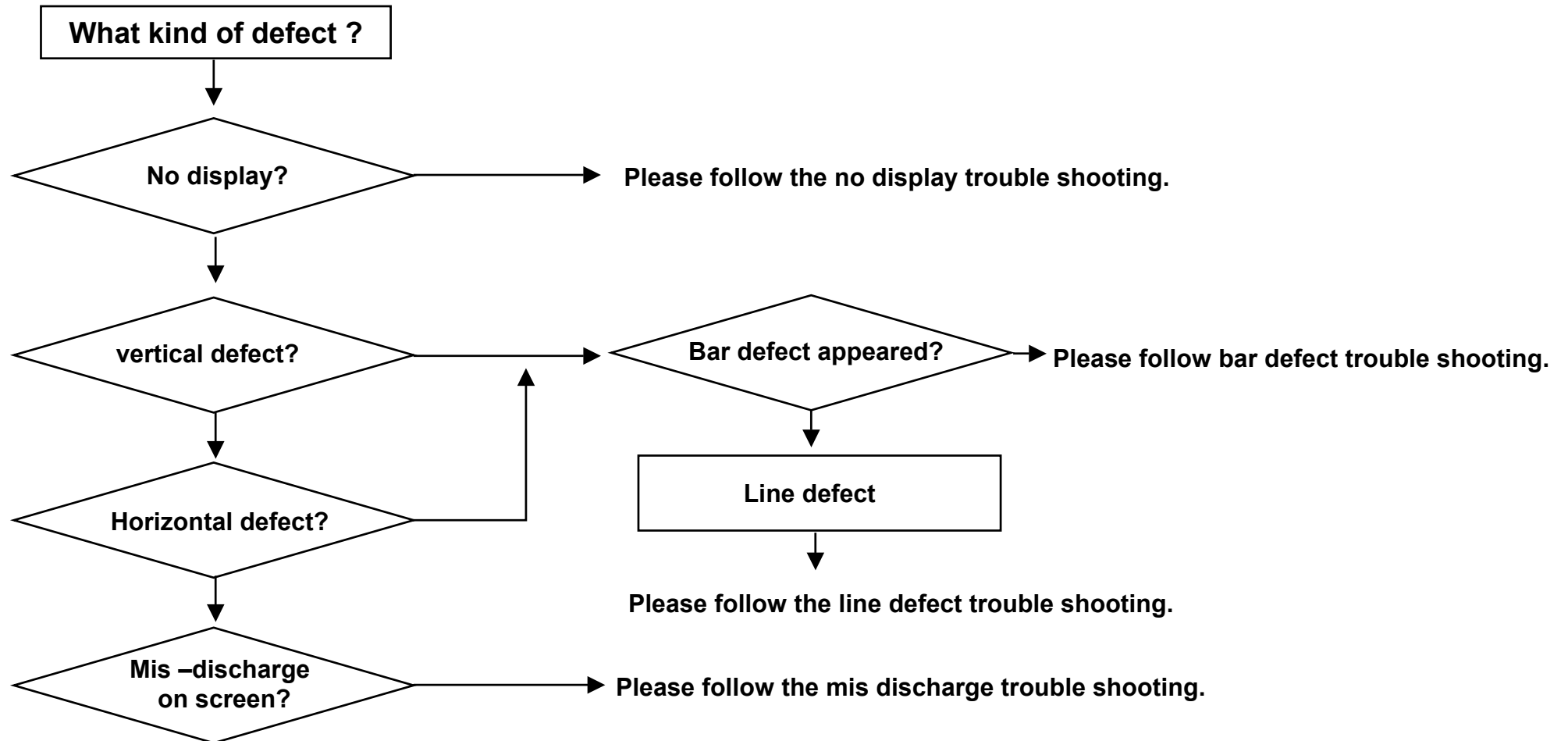

4. Trouble shooting.

• *No display*

Check each section with following method if there is problem, replace or repair that part.

If not go to the next section.

1. Connector

Confirm every Connector (PSU, Y-SUS, CTRL, Z-SUS)

module may not be normal by mis-connection which can not send signal and power.

Also Mis connection for a long time has a specific b/d failed.



CTRL B/D + Y-SUS

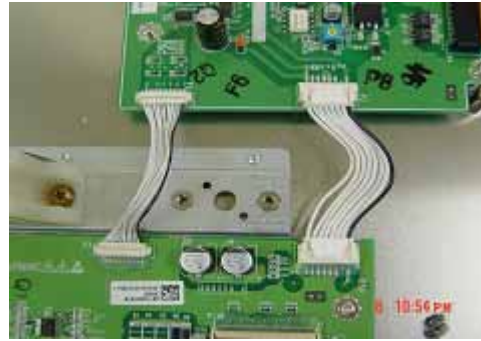

CTRL B/D + Z-SUS



CTRL B/D + X-B/D

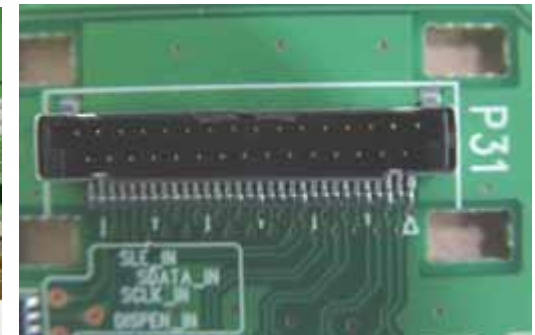

Signal input(LVDS)

4. Trouble shooting.

2. Exhaust tip Crack

Confirm exhausting Tip and find Crack with naked eyes to check vacuum state.

If there is problem replace the module .

in case of vacuum breakdown, module makes a shaking noise because of inside gas ventilation.

(there may be a small crack which could not see with naked eyes. And this noise is different from Capacitor noise.)

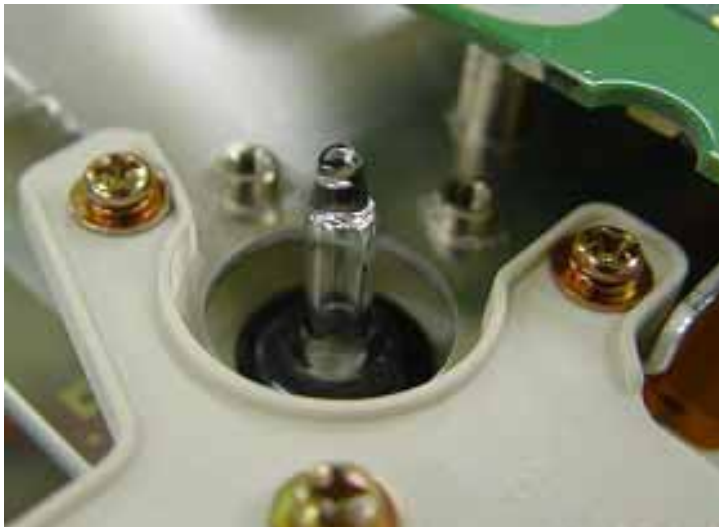

NORMAL

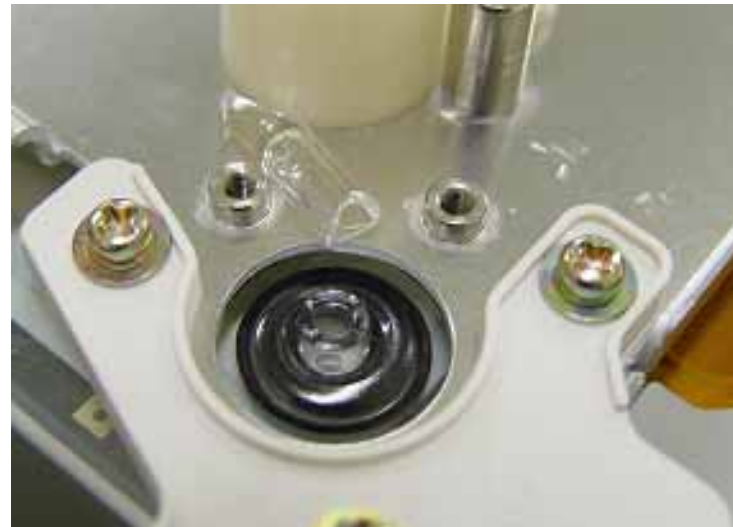

CRACKED

4. Trouble shooting.

3. PSU(Power Supply Unit)

1. Check each unit part of PSU inside with naked eyes.
(capacitor, FET, a kind of IC, resistor)
2. Check FUSE and SW1 (on Normal).
3. Check Output voltage which is converted from AC V to DC V.

voltage Check (5V, Va, Vs)

When PSU Protection occurred. Check Short between Y-SUS, Z-SUS B/D .

Confirm
input voltage

if not same

Adjust
voltages



MODEL : PDP42V6####
All Voltage : DC(=) 5.2V
Va : 65V Vs : 188V
200 / -75 / 115 / N.A / N.A
Max Watt : 250W(Full White)

Multi-meter Touch point
(5V, Va ,Vs must accord with Module Label)

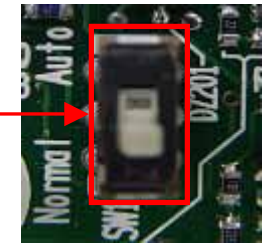
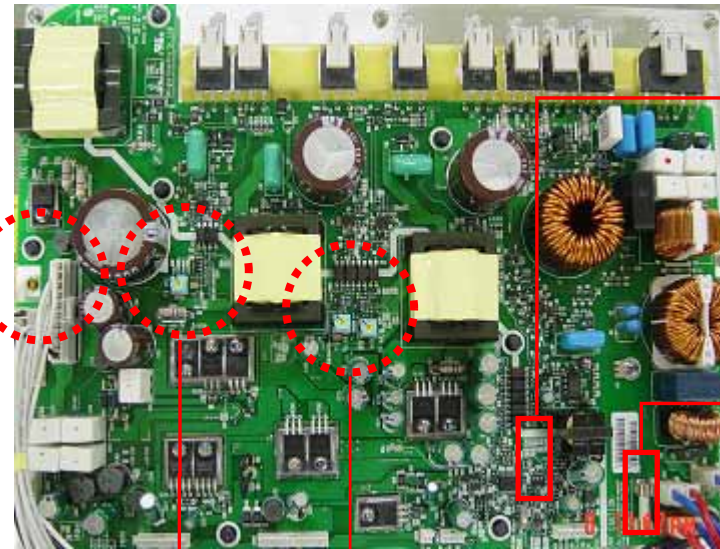

SW1 Normal

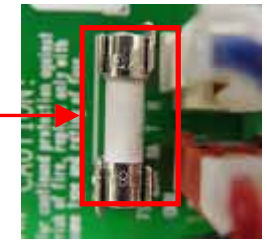

Fuse open check

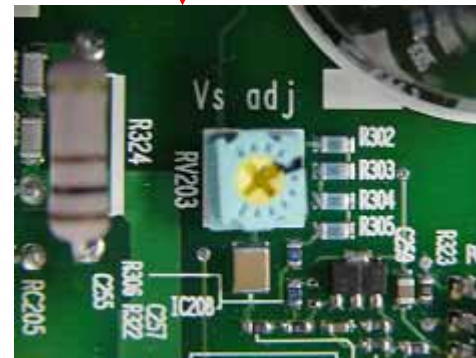

Vs Voltage ADJ
(Vs : About 180 ~195 V)

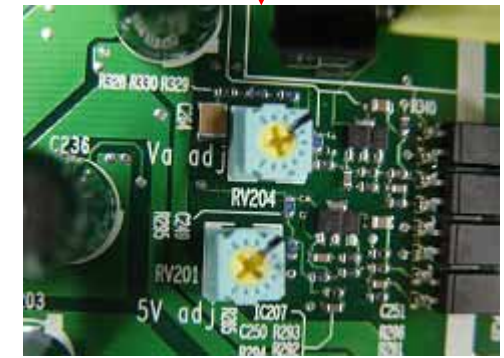

Va, 5V(VCC) Voltage ADJ
Va : About 55 ~65 V
5V(VCC) : 5V~5.5V)

4. Trouble shooting.

4. Ctrl B/D

1. Confirm LED D17(flashing) ,13 lighting
2. If not CHECK OSC X1 output.
3. Check CTRL input voltage
(CONNECTOR P300)
4. CHECK 3.3V, 5V,15V.
5. Check IC 11 3.3V
IC 3 2.5V

OSC(X1)

Probe
Touching
point



Check oscillating state.
(normal 100 MHZ)

Be careful with physical shock.

Input voltage

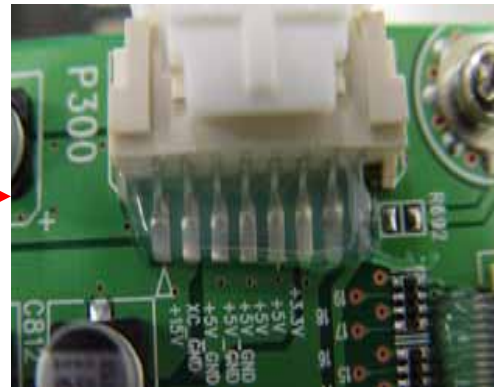

Diode

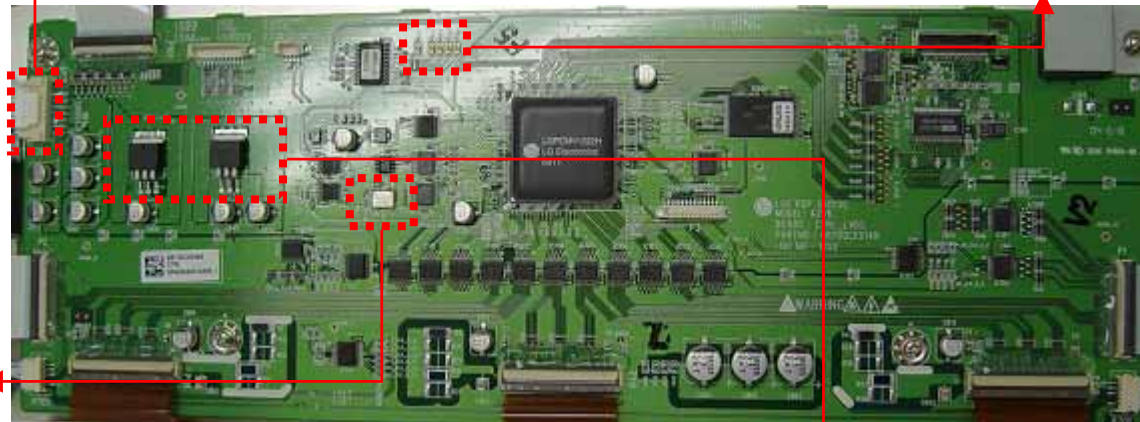
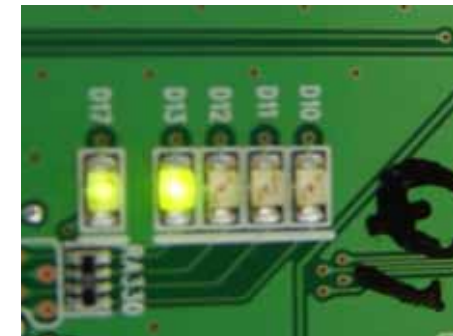

Check IC 11,13

DMM +
DMM - (GND)



4. Trouble shooting.

5. Y-sus B/D

1. Check FUSE [FS1(5v) ,FS2(Vs)].
2. Check voltages(Vsetup,-Vy, Vscw)
3. Check DIODE between GND and Y SUS output.
[SUSUP(OC2) SUSDN(OC1)].
forward=0.4 ,reverse=OVERLOAD.
4. Check whether output voltages agrees
with voltage that represented in label.

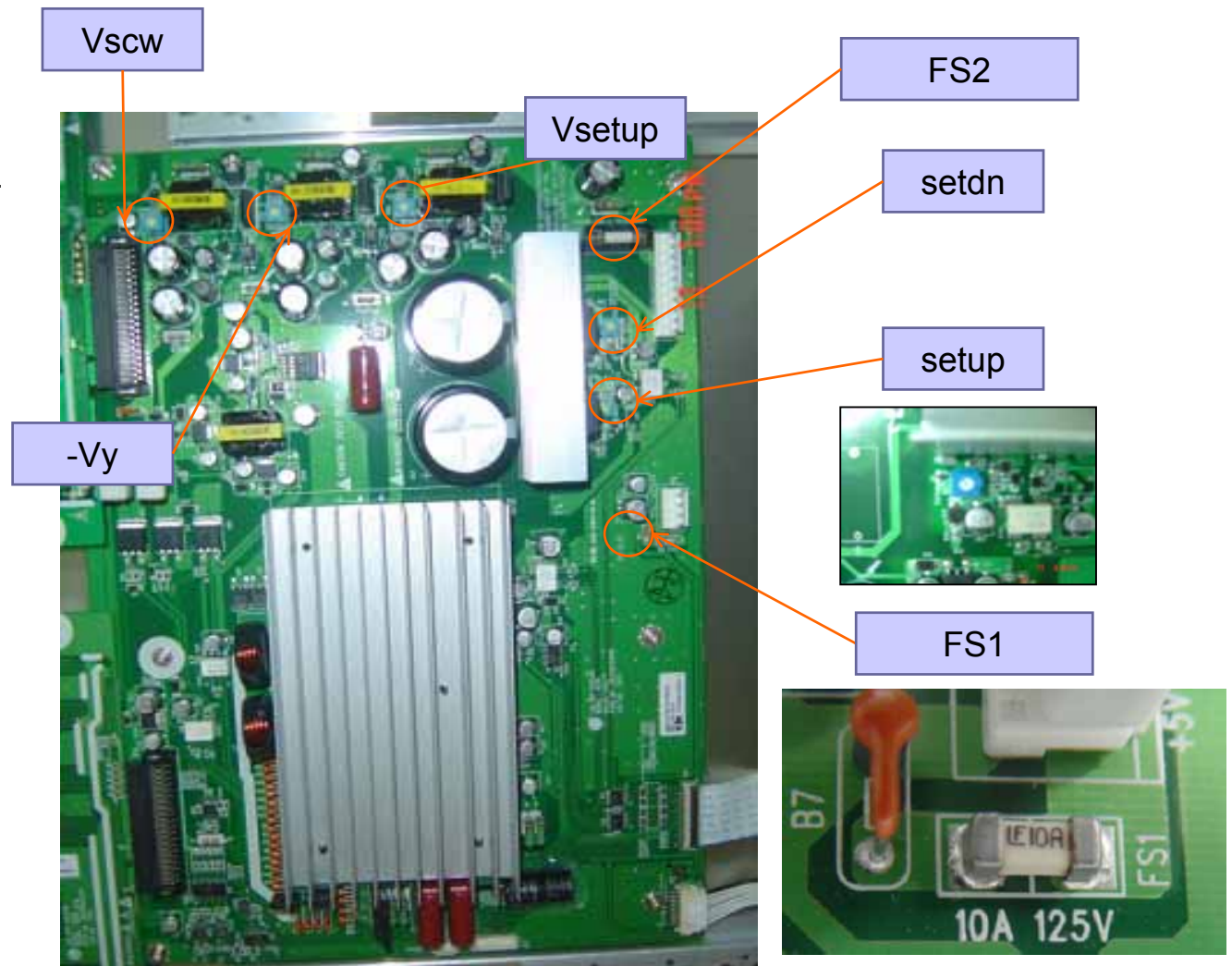

4. Trouble shooting.

Check whether output voltages agrees with voltage that represented in label.

Check diode value GND between Y-SUS output.



Normal diode value= 0.4 (forward)

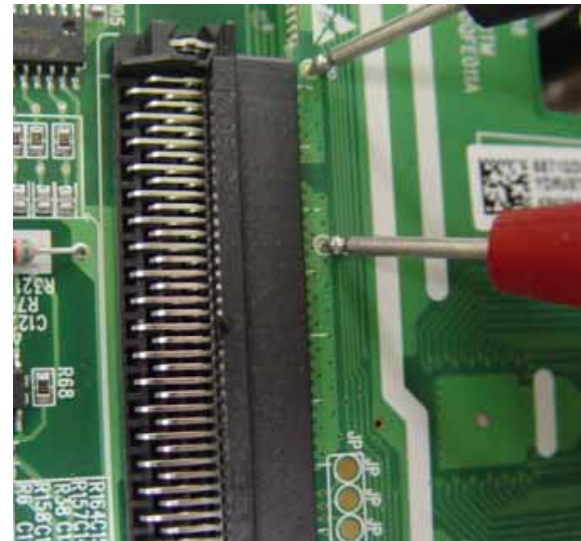

Normal diode value = OL (reverse)

4. Trouble shooting.

6. Z-sus B/D

1. Check the FUSE.
2. Check input voltages.(Va, 5V,15V)
3. Check FPC out put diode value.
4. Check ramp waveform.

Check the FUSE

5V FUSE

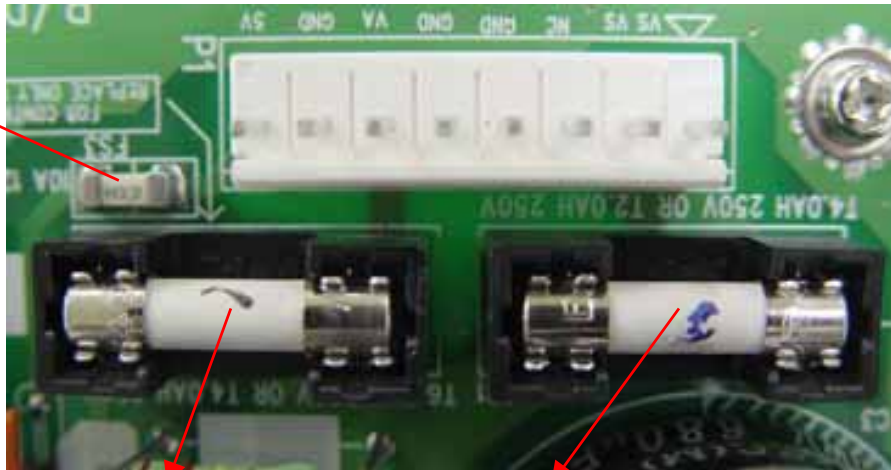

Va FUSE 6.3A

Vs FUSE 2A or 4A

Check input voltages

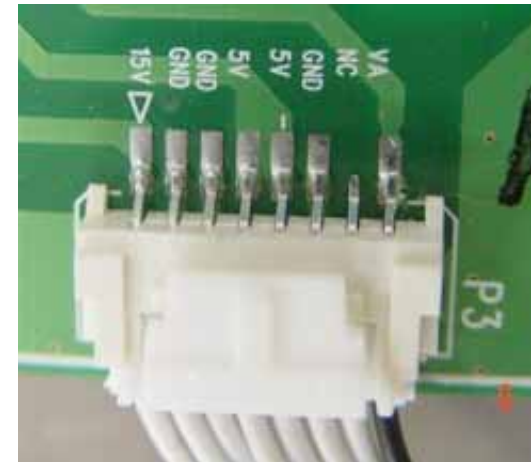

4. Trouble shooting.

Variable resistance of Z RAMP
waveform slope.

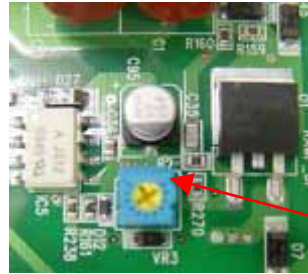

Check FPC output diode value.

caution: check certainly after removing FPC.



Normal diode value=0.375(forward)



Normal diode value=OVER LOAD(reverse)

4. Trouble shooting.

Power protection

It is power protection when power is off automatically within 2~3 min. from power on.

Power protection function protect the boards when occurred short on circuits of PDP module or power problem.

If can not impress power even after replacing PSU, find out where the short occurred.

* PSU makers.

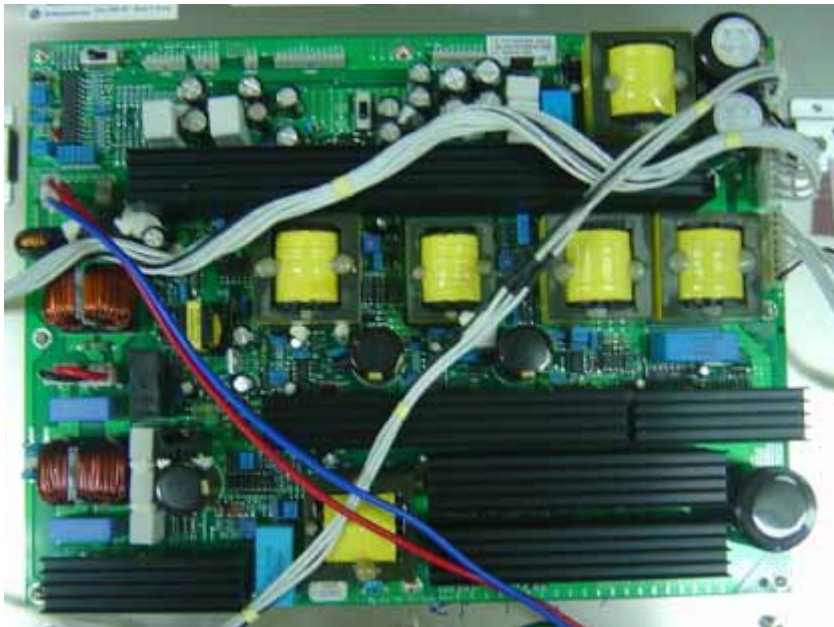

DAEGIL PSU



UNICON PSU

4. Trouble shooting.

• Vertical defect (bar)

Check each section with following method if there is problem, replace or repair that part.

If not go to the next section.

1. Connector

Check COF connector.

If not connected well, it will Make a bar defect .

Check here



Bar

Check here

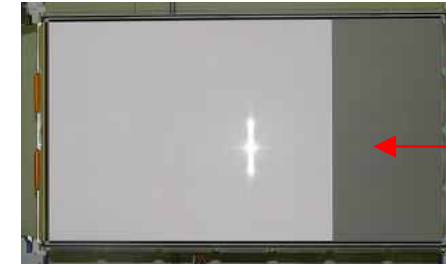
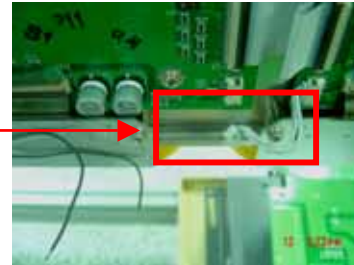

Off

2. Checking COF

Confirm whether COF was torn. And then check input of COF resistor and IC.

Tearing

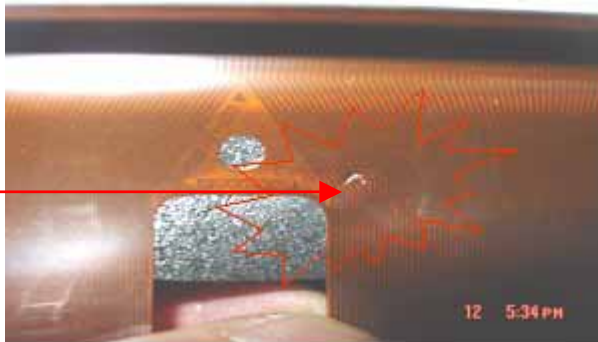

COF 6 is torn partly



4. Trouble shooting.

Checking address COF input of resistor and IC

COF resistor checking

Check the both side of resistor With Digital multi meter(DMM) .

If the resistor is normal, the resistor value will be 10.2 ~ 10.8

But if not, the value will be 0 or infinity and replace the resistor.

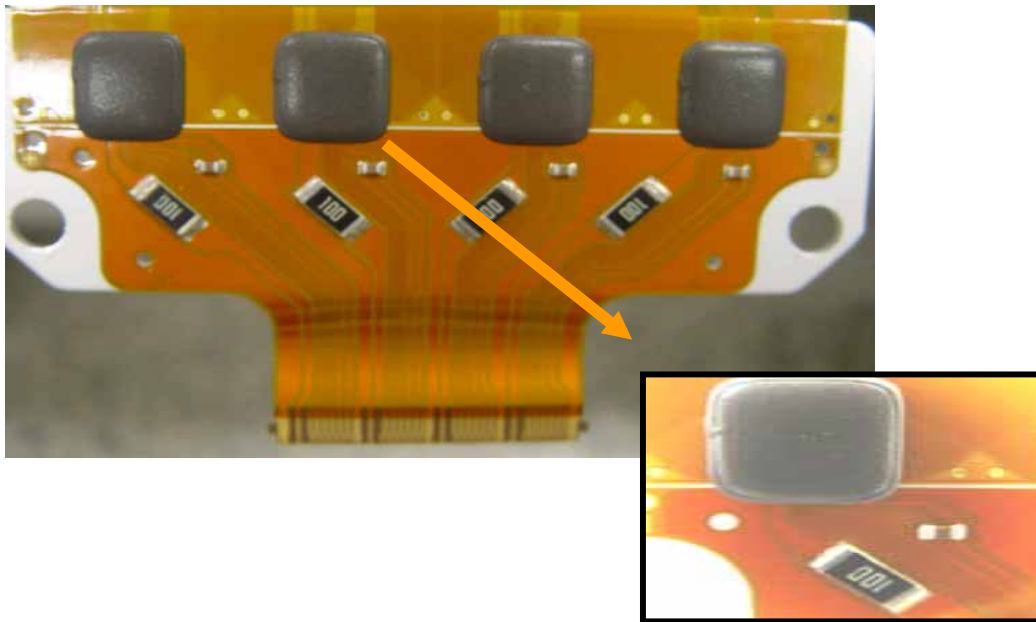

4. Trouble shooting.

Checking address COF input of resistor and IC

IC input checking

Inside of IC , there is 4 ea diodes which separated in 2 series .

(input 2, output 2)

*how to check

1.contact DMM - terminal to a right terminal of condenser(GND)

and DMM + terminal to a right terminal of IC, normal value 0.66 (fig.1)

2.contact DMM - terminal to Output terminal of resistor, and

DMM + terminal to a right terminal of IC , normal value 0.73 (fig.2)

Fig. 1

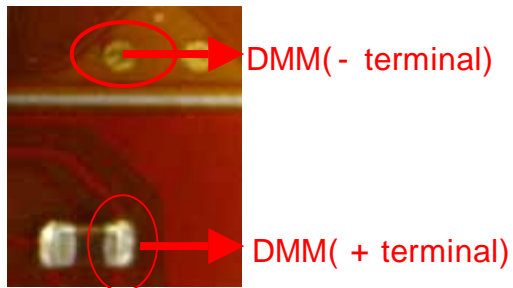
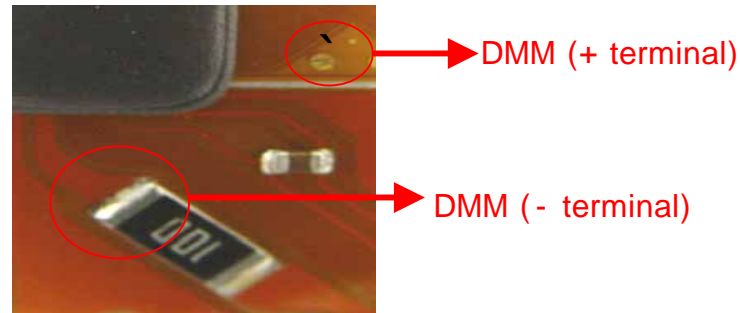

Fig. 2



4. Trouble shooting.

3. Ctrl B/D

CTRL B/D supplies video signal to COF. So if there is a bar defect on screen, It may be the ctrl b/d problem.

A flow of address signal

In this figure, we can easily suppose what will be appeared on screen when a specific part failed.

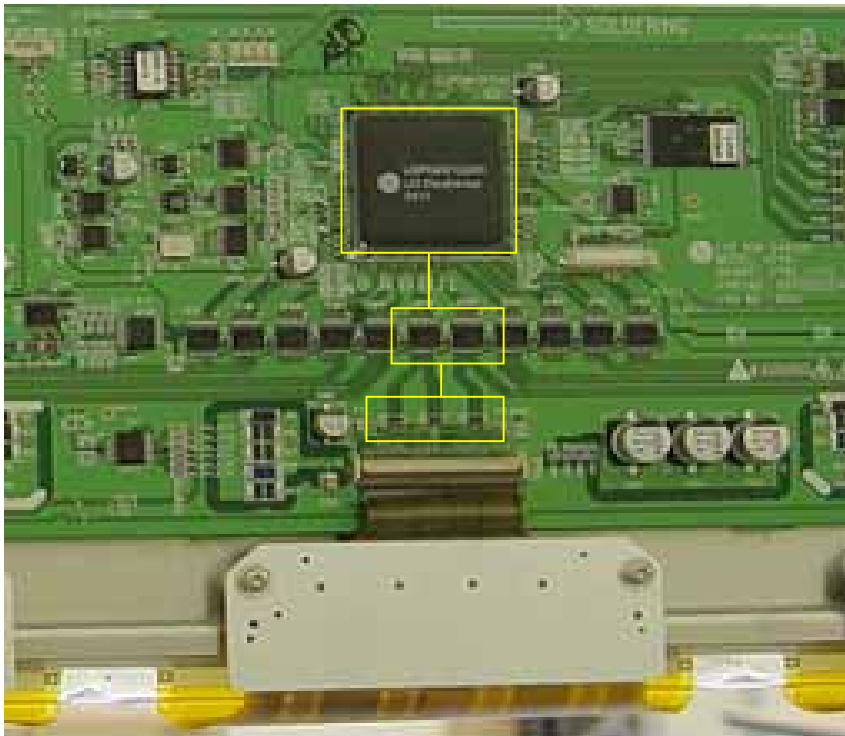

<Diagram of ctrl b/d>

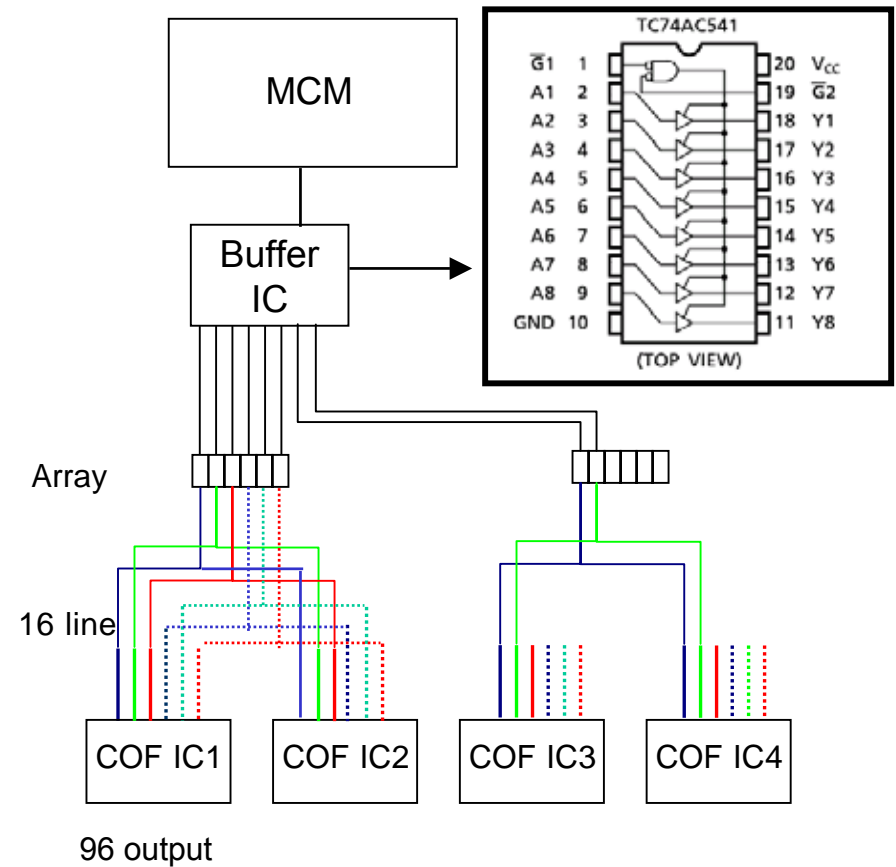

4. Trouble shooting.

Vertical defect (line)

In case of 1 line open or short , check foreign substances in COF connector.

First blow up foreign substances with your mouth. And then if the same line appears, replace the panel.

1 line open or short

This phenomenon is due to COF IC inside short or adherence part of the Film and rear panel electrode problem.
In this case, replace the panel.

1 electrode open



1 line open



Line open or short with same distance.

This is MCM of Ctrl b/d defect. MCM can not be replaced separately. So replace the ctrl b/d.

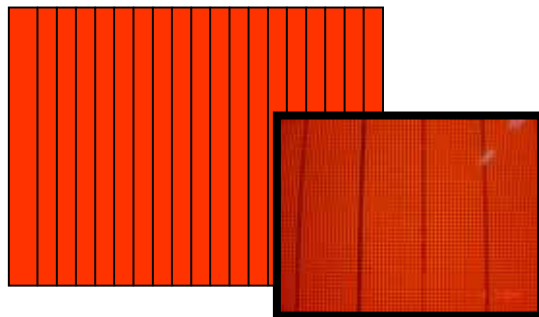

MCM (Multi Chip Module)



4. Trouble shooting.

line defect from each parts

- **Case 1: Buffer IC fail**

COF IC 1,2 192 line(96+96) open.

COF IC 3,4 64 line open (with fixed interval there is on,off Repetition)

- **case 2 : Array resistor fail**

COF IC1 16 line , COF IC2 16 line open

- **case3 : COF IC fail**

96 line open.

16 line open

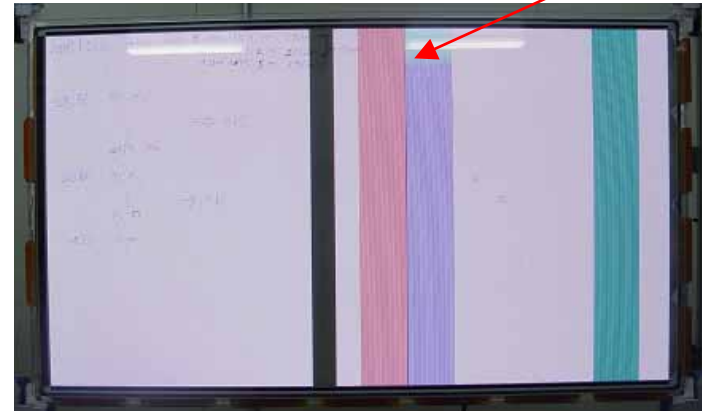

96 line open

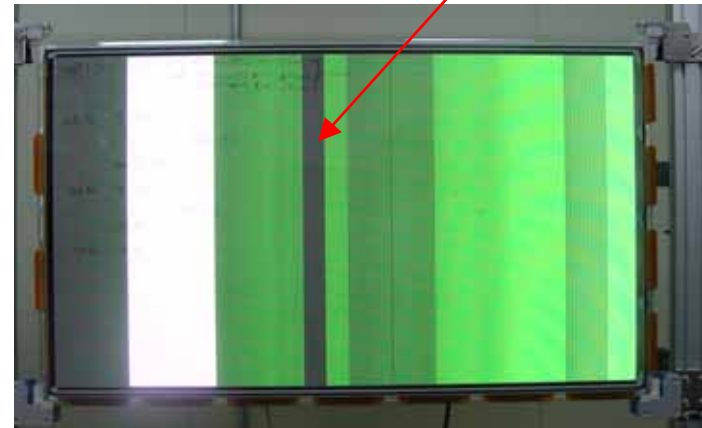

4. Trouble shooting.

• *Horizontal (bar)*

Most horizontal defects can be repaired. In case of adherence part of the Film and rear panel electrode defect or panel electrode open,short , replace the panel.

1. Connector

It can make a horizontal bar that connector on Y b/d and Z b/d did not plugged well. Because sustain voltage can not be supplied to panel. So check connectors (FPC, Y drv –Y drv) first.

Disconnected



Disconnected

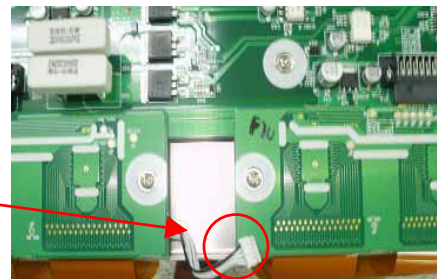

Horizontal bar

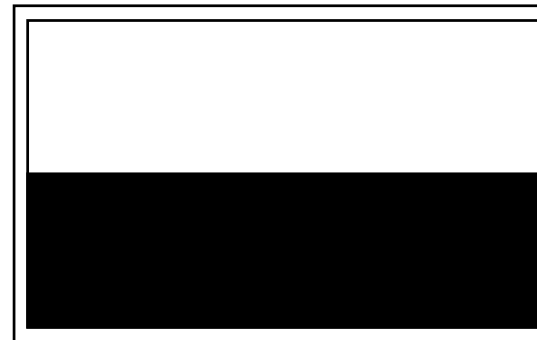

Screen off

4. Trouble shooting.

2. Scan IC check

Check diode value of the right side part of output pin.



Normal diode value. (in case of Panasonic IC=1.035)



Defect diode value= 0.018

* It can be different from each IC Maker. (in case of TI IC= 0.6~0.7)

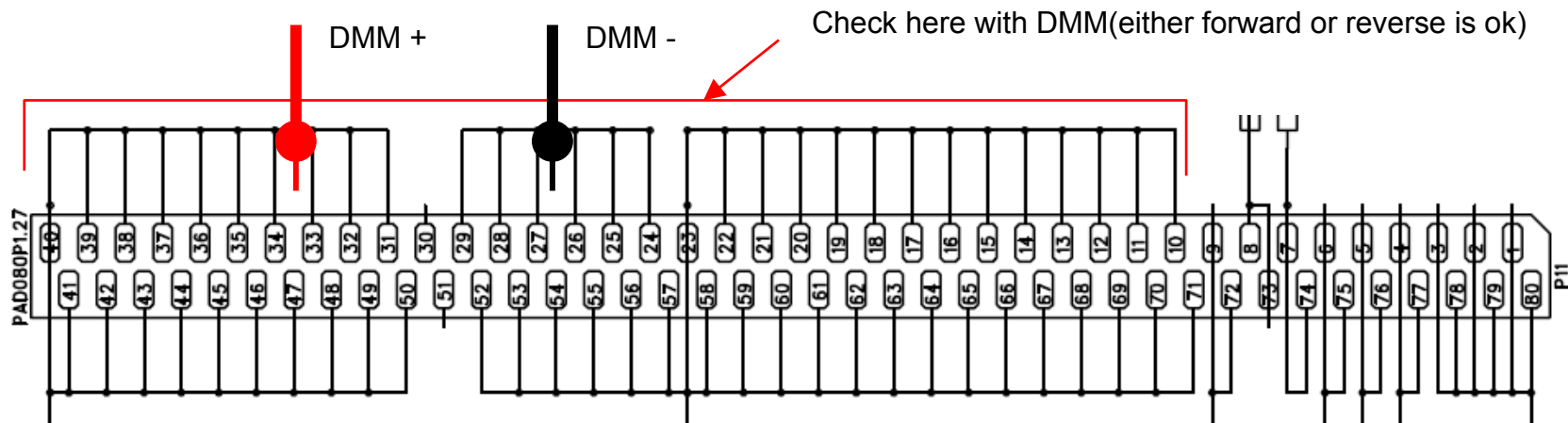

4. Trouble shooting.

• *Horizontal (line)*

1. Check FPC

In case of horizontal 1 or more line, it is due to FPC or panel inside .
ctrl b/d, Y b/d is just normal.

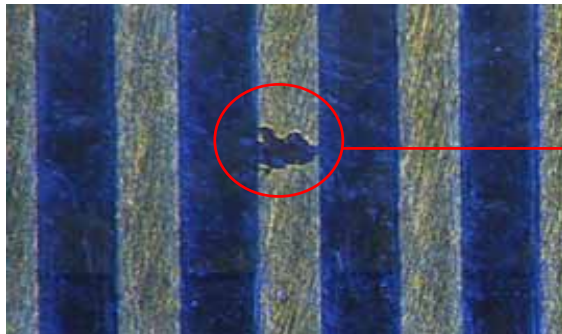

FPC electrode open



Panel electrode
Insulation break down

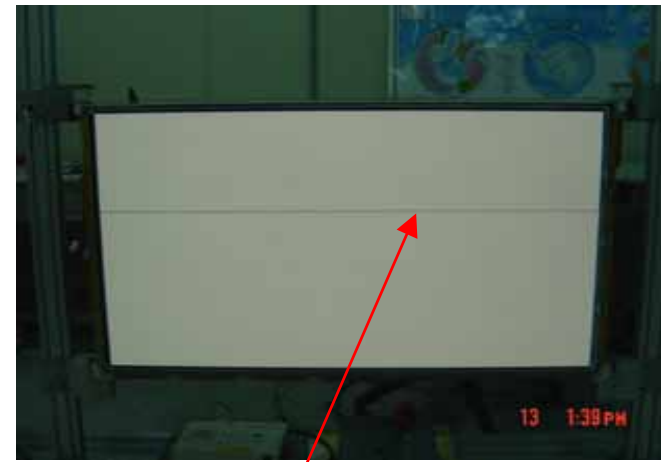

Horizontal 1 line.

2. Check scan IC

Check with same method that presented in Horizontal (bar).

4. Trouble shooting.

How to check IPM

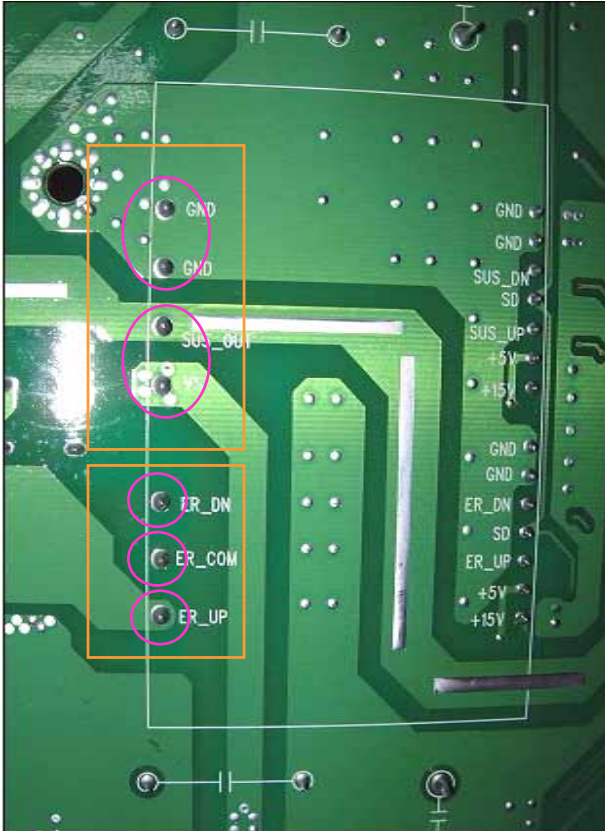

Forward : test 1 GND(+) , Sus-out(-)
2 Sus-out(+),Vs(-)
3 ER-DN(-),ER-COM(+)
4 ER-COM(-),ER-UP(+)

when each 4 TEST Diode value is over 0.4V => **OK**

Reverse : test 1 GND(-) , Sus-out(+)
2 Sus-out(-),Vs(+)
3 ER-DN(+),ER-COM(-)
4 ER-COM(+),ER-UP(-)

when each 4 nodes TEST Diode value is infinity => **OK**

Specially, the value of ER-UP,COM, DN in the Y/Z board, should be checked all of them. but, the terminal of Vs,Sus-out,GND, we must aware to know after check one of IPM because it is parallel.

→ if no problems, check 15V(Y,Z B/D) with GND, → Forward value 0.3V,
Reverse value infinite. If no problems,

Product Specification of PDP Module



General

- 1) Do not place this product in a location that is subject to heavy vibration, or on an unstable surface such as an inclined surface. The product may fall off or fall over, causing injuries.
- 2) When moving the product, be sure to turn off the power and disconnect all the cables. While moving the product, watch your step. The product may be dropped or fall, leading to injuries or electric shock.
- 3) Do not place this product in a location that is subject to heavy vibration, or on an unstable surface such as an inclined surface. The product may fall off or fall over, causing injuries.
- 4) Before disconnecting cable from the product, be sure to turn off the power. Be sure to hold the connector when disconnecting cables. Pulling a cable with excessive force may cause the core of the cable to be exposed or break the cable, and this can lead to fire or electric shock.
- 5) This product should be moved by two or more persons. If one person attempts to carry this product alone, he/she may be injured.
- 6) This product contains glass. The glass may break, causing injuries, if shock, vibration, heat, or distortion is applied to the product.
- 7) The temperature of the glass surface of the display may rise to 80°C or more depending on the conditions of use. If you touch the glass inadvertently, you may be burned.
- 8) Do not poke or strike the glass surface of the display with a hard object. The glass may break or be scratched. If the glass breaks, you may be injured.
- 9) If you glass surface of the display breaks or is scratched, do not touch the broken pieces or the scratches with bare hands. You may be injured.
- 10) Do not place an object on the glass surface of the display. The glass may break or be scratched.

Spare Part List for PDP4210EA

Item	Part Number	Part Description	Usage / Unit	Unit
1	E6205-001003	42" ED PDP Module	1	Piece
2	900-420103-01B	42" Glass Filter	1	piece
3	E7801-100001	Main PCBA	1	set
4	E7801-100002	Audio PCBA	1	set
5	771S42D101-01	ATSC PCBA	1	set
7	771-42D111-01	Control PCBA	1	set
8	771-42D111-02	IR PCBA	1	set
9	E4101-027001	Power Switch	1	piece
10	E4801-116002	Speaker	2	piece
11	E3301-028005	Speaker Terminal (without cable)	1	piece
12	E3404-157004	AC Power Cord	1	piece
13	E3421-926080	LVDS Cable	1	piece
14	E3421-925049	Connection Cable 1	1	piece
15	E3421-926083	Connection Cable 3	1	piece
16	E3421-926084	Connection Cable 4	1	piece
17	E3421-927001	Power Switch Cable 1	1	piece
18	E3421-927002	Power Switch Cable 2	1	piece
19	E3421-926081	Control PCBA Cable	1	piece
20	E3421-926094	IR PCBA Cable	1	piece
21	E7501-051007	Remote Control	1	set
22	E7301-010002	AAA size Battery	1	pair

Spare Part List for PDP4210EA

Item	Part Number	Part Description	Usage / Unit	Unit
23	200-42D131-MTK02AV	Front Plastic Frame	1	piece
24	277-42D101-01S	Function Knob	1	piece
25	263-42D101-01S	Power Lens	1	piece
26	269-42D101-01L	IR Lens	1	piece
27	481-42D107-01S	PCBA Shield Box	1	piece
28	483-42D103-01	PCBA Shield Top Cover	1	piece
29	436-42D118-01S	Terminal Frame	1	piece
30	402-42D114-01S	Metal Back Cover	1	piece
31	423-42D11E-01S	Power Switch Metal Frame	1	piece
32	510-42D101-MTU02K	Top Carton Box	1	piece
33	511-42D111-01K	Bottom Carton Box	1	piece
34	300-42D106-02C	Top Cushion	1	piece
35	300-42D105-02C	Bottom Cushion	1	piece
36	244-34B811-01	Carton Box Handle	2	piece
37	310-504004-01	Poly bag for Main Unit	1	piece
38	310-111404-07V	Poly bag for Instruction Manual	1	piece
39	580-P42AAEM-TU02L	Instruction Manual	1	piece
40	388-42SB04-01H	Power Socket Plate	1	piece
41	388-42D103-01H	Caution Plate	1	piece
42	387-42AA01-MTU02H	Model Plate	1	piece
43	388-42SB02-01H	Speaker Terminal Plate	1	piece
44	384-42D103-MTU01H	Terminal Plate	1	piece
45	590-42AA01-04	Warranty Sheet	1	piece

Spare Part List for PDP4210EA

Item	Part Number	Part Description	Usage / Unit	Unit
46	579-42D102-09	Model Plate Serial Number	1	piece
47	579-42AA01-05	Bar Code Label	1	pair
48	579-42D103-02	ON/OFF Label	1	piece
49	568-P46T02-02	Warning Label	1	piece
50	734-BP0302-01	Duck Feet Stand	1	set

NOTE : THIS RELEASED DRAWING WAS PRODUCED BY COMPUTER , DO NOT UPDATE MASTER MANUALLY

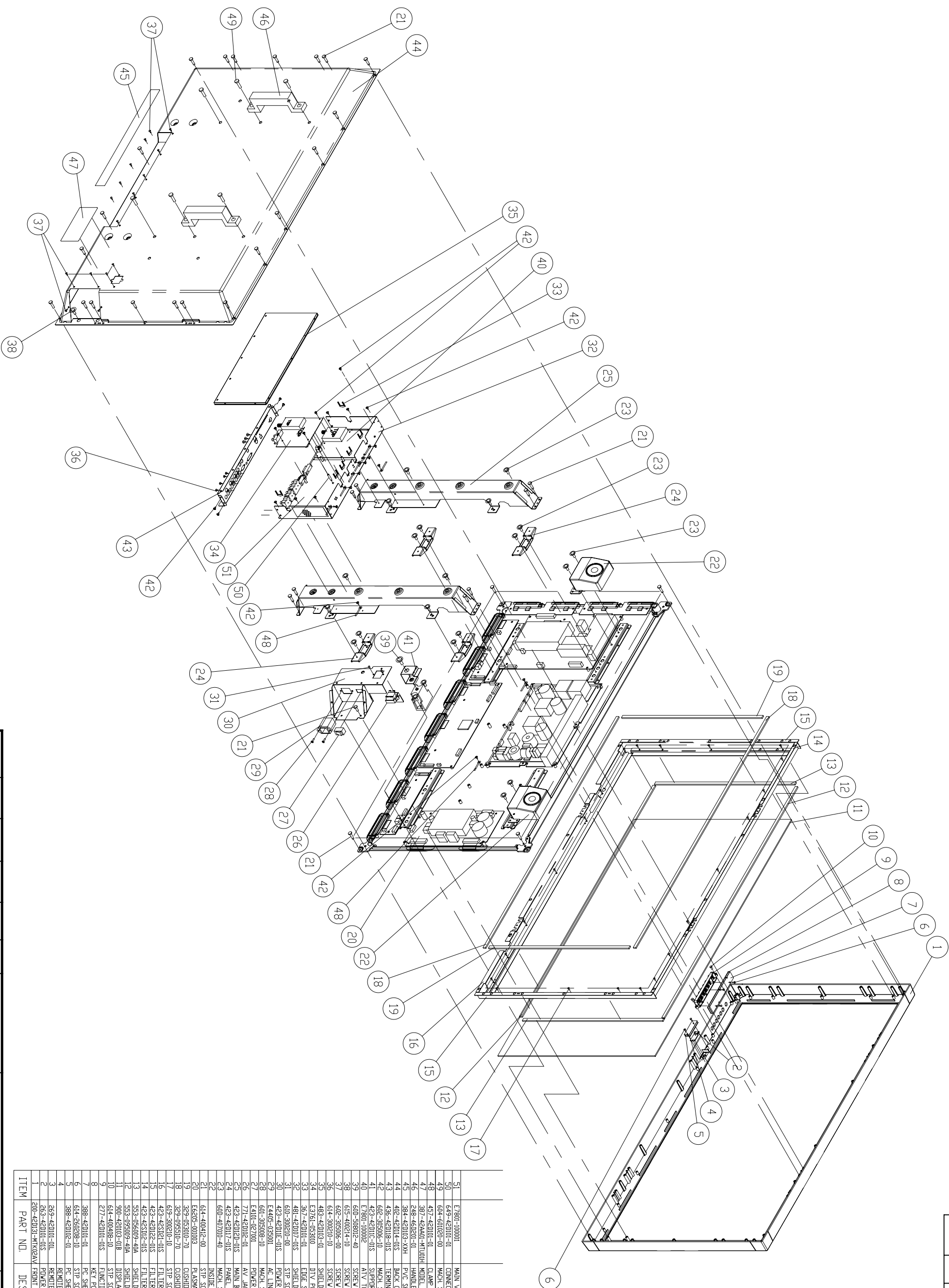

DWG. REV.	ZONE	DESCRIPTION	DATE	REVISOR

ITEM	PART NO.	DESCRIPTION	QTY	REMARK
51	E7801-100001	MAIN VSC PCB	1	
50	649-421001-01	CONNECT BESS	1	
49	604-601020-00	MACH. SCREW M6X20	6	
48	457-421001-01	CLAMP	11	
47	387-424001-M11100H	MODEL. PLATE	1	
46	248-462020-01	HANDLE	2	
45	384-421003-XH	PVC SHEET FOR MAIN BOARD	1	
44	408-421014-01S	BACK COVER	1	
43	438-421018-01S	TERMINAL SHEET	1	
42	608-405006-10	MACH. SCREW 3/16	41	
41	423-42101C-01S	SUPPORT FOR PW BKT	1	
40	E7801-100002	A1V TUNER PCB	1	
39	600-508012-40	SCREW 5/12	1	
38	615-400214-10	SCREW 4X14	1	
37	608-405006-00	SCREW 3X10	16	
36	614-300210-10	SCREW 3X10	5	
35	483-421003-01	SHIELD COVER e-room	1	
34	E3781-050300	DRIVE PCB	1	
33	387-421001-01	EDGE SHIELD LAMM	6	
32	387-421001-01S	SHIELD BOX SHANUL	1	
31	618-300210-01S	STP. SCREW 3X10	2	
30	423-42101E-01S	POWER BKT FOR VS/V6	1	
29	E4405-033901	AC LINE FILTER	1	
28	601-305008-10	MACH. SCREW 3/8	2	
27	E4101-027001	POWER SWITCH	1	
26	771-42101E-01	AV JACK PCB	1	
25	423-42101D-01S	MAIN BKT FOR VS/FRM/ISA	2	
24	423-421017-01S	PANEL PA10H FOR V6	4	
23	600-407001-40	MACH. SCREW W/SP WASHER 4X10	21	
22	614-400412-00	STP. SCREW 4X12	34	
21	E6205-000003	PLASMAS module LG 42X2	1	
20	329-053010-70	CUSHION 530X10X7MM	2	
19	329-053010-70	CUSHION 955X10X7MM	2	
18	619-300210-10	STP. SCREW 3X10	22	
17	423-423021-01S	FILTER SUPPORT B1M	1	
16	423-42101E-01S	FILTER SUPPORT L&R	2	
15	423-423012-01S	FILTER SUPPORT TOP	2	
14	553-056009-40A	SHIELD GASKET 500X9X2.9MM	2	
13	553-056009-40A	SHIELD GASKET 950X9X2.9MM	2	
12	553-056009-40B	DISPLAY FILTER GLASS	2	
11	900-421003-01B	STP. SCREW 4X8	2	
10	614-400408-10	STP. SCREW 4X8	1	
9	277-421001-01S	FUNCTION KNDR	1	
8	388-421001-01	KEY PCB	1	
7	388-421001-01	PC SHEET FOR KEY PCB	1	
6	614-260208-10	STP. SCREW 2.6X8	5	
5	388-421002-01	PC SHEET FOR REMOTE PCB	1	
4	388-421002-01	REMOTE PCB	1	
3	269-421001-01L	REMOTE LENS	1	
2	263-421001-01S	POWER LENS	1	
1	200-421013-MIK02AV	FRONT CABINET	1	

Exploded View

DRAWN.	TOLERANCE UNLESS OTHERWISE SPECIFIED	KAWA ELECTRONIC R & D CENTRE	TITLE	PD42EALUSXM1-A02
CHECKED	0. MM ~ 8. MM ± 0.1		MODEL NO.	PP4210EA
APPRD.	8. MM ~ 25. MM ± 0.15		PART NO.	
	25. MM ~ 80. MM ± 0.2		DWG. NO.	
	80. MM ~ 250. MM ± 0.3		SCALE NIL	
	250. MM ~ ABOVE ± 0.6		QTY.	
	ANGULAR: ± 1		SHEET 1 OF 1	

If you forget your V-Chip Password

- Omnipotence V-Chip Password: 8205.

Using the “Change Password” item

- ❶ When enter the “Parental” menu, select “Change Password”.
- ❷ Press ▲ or ▼ button to highlight the “Change Password” item.
- ❸ Press **Enter** button to confirm and pop up a menu.

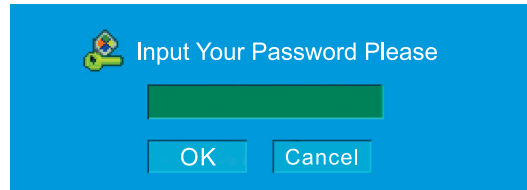

- ❹ Use 0~9 buttons input the omnipotence password(8205), then Press **Enter** button to enter and pop up a menu.

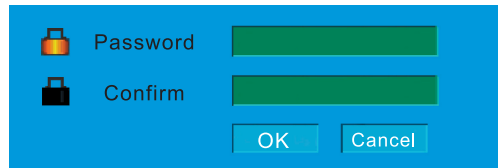

- ❺ Use 0~9 buttons input your new password.
- ❻ Press ▼ button to move to confirm blank.
- ❼ Use 0~9 buttons input your new password again.
- ❽ Press **Enter** button to confirm

-Suggest: Change to your familiar Password again.

Software upgrade

Process of update MT8205AE

Preparing :

- 1) Connect RS232-VGA download line, One connector is connected to VGA connect port of Plasma TV while another side is connected to PC COM port.
- 2) Store the MtkTool into the PC .

Downloading :

- 3) Turn on AC power and wait TV entering standby mode, while the color of the power indicator is Red.
- 4) Execute MTKtool and select the chipset as MT8205. (the software of MTKtool will be sent to your side)

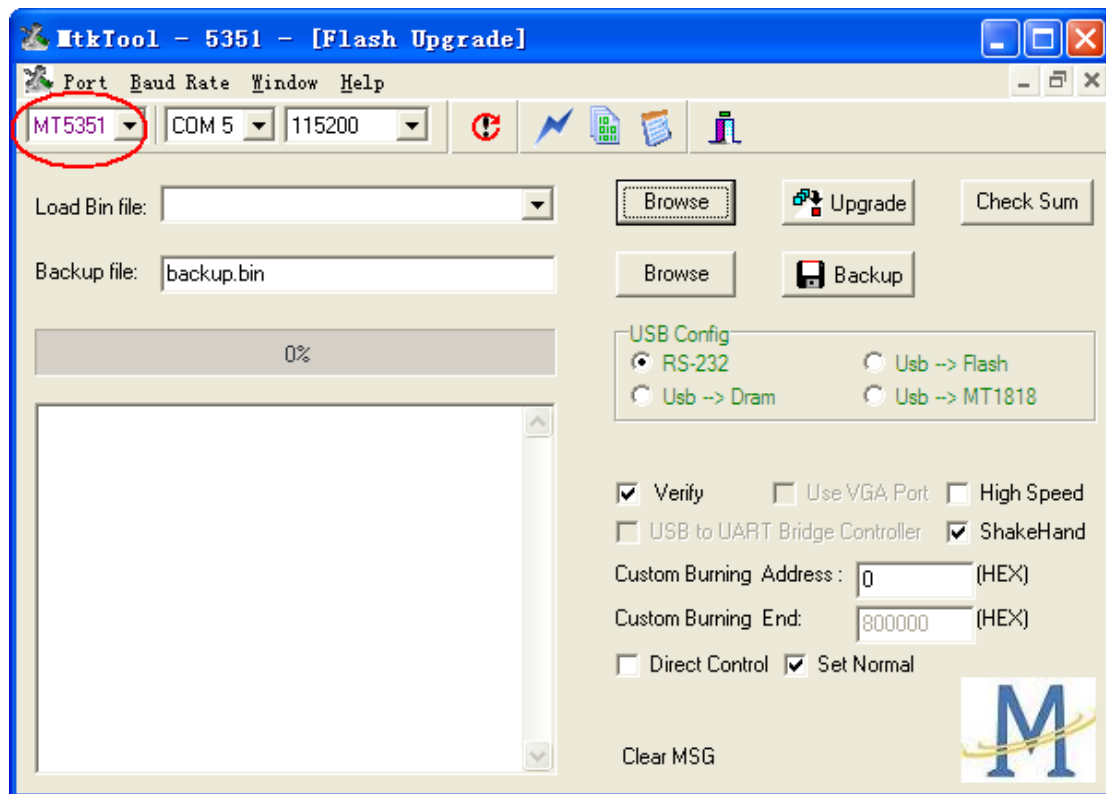

- 5) Select current COM port. (please try to check the COM port of your PC).

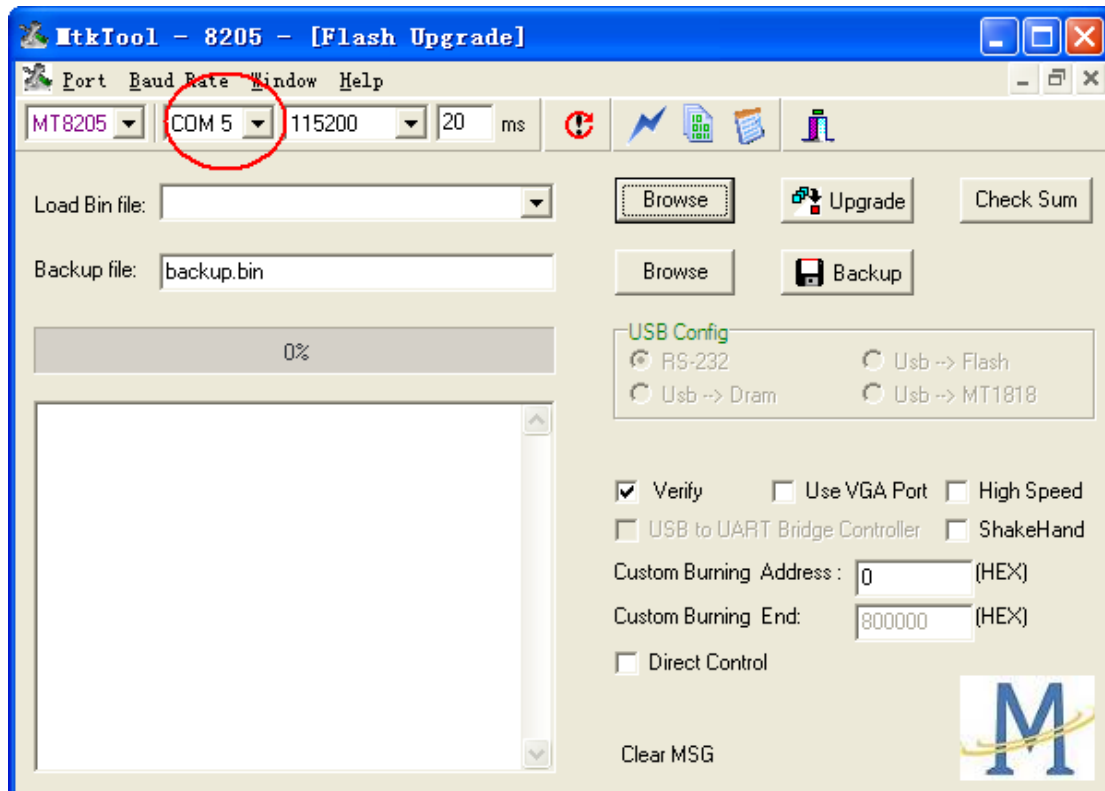

6) Choose the bit rate as 115200.

7) Select the update binary by pressing browse button. For example, the binary file name is PDP4210EA_VIORE_XXXXXX_XXXX_VXX.bin. (this update firmware will be sent to your side)

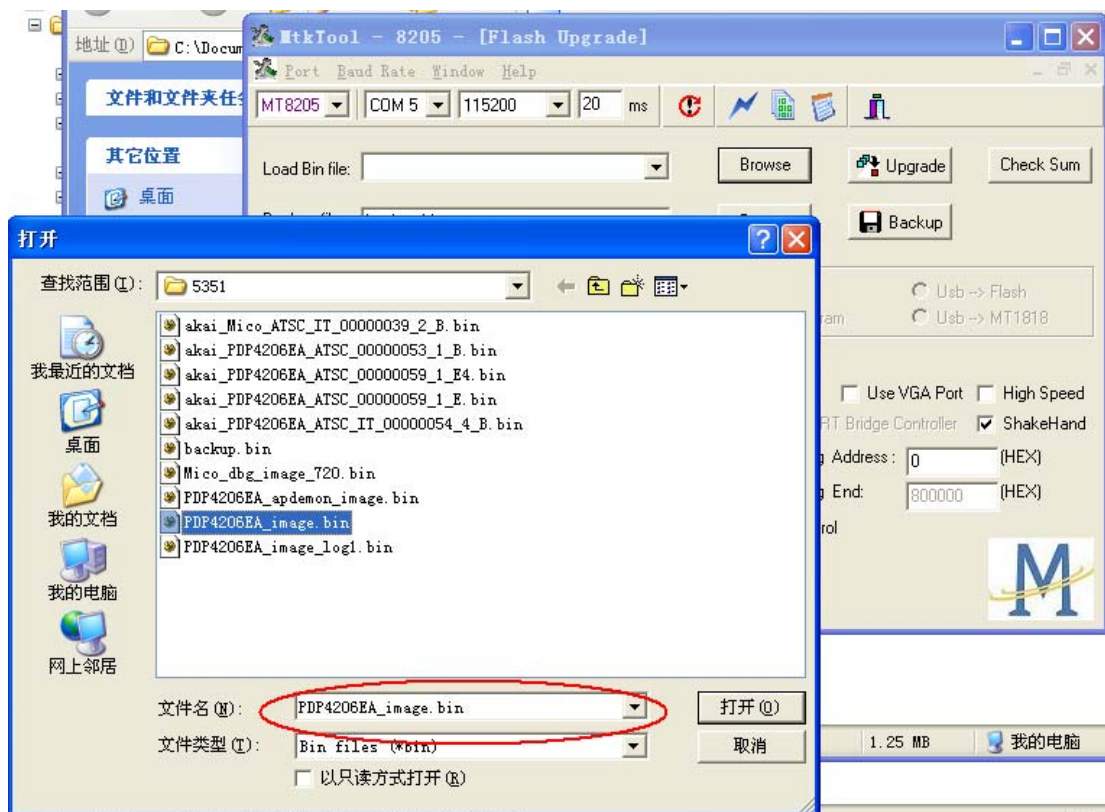

8) Press Upgrade button and start update process.

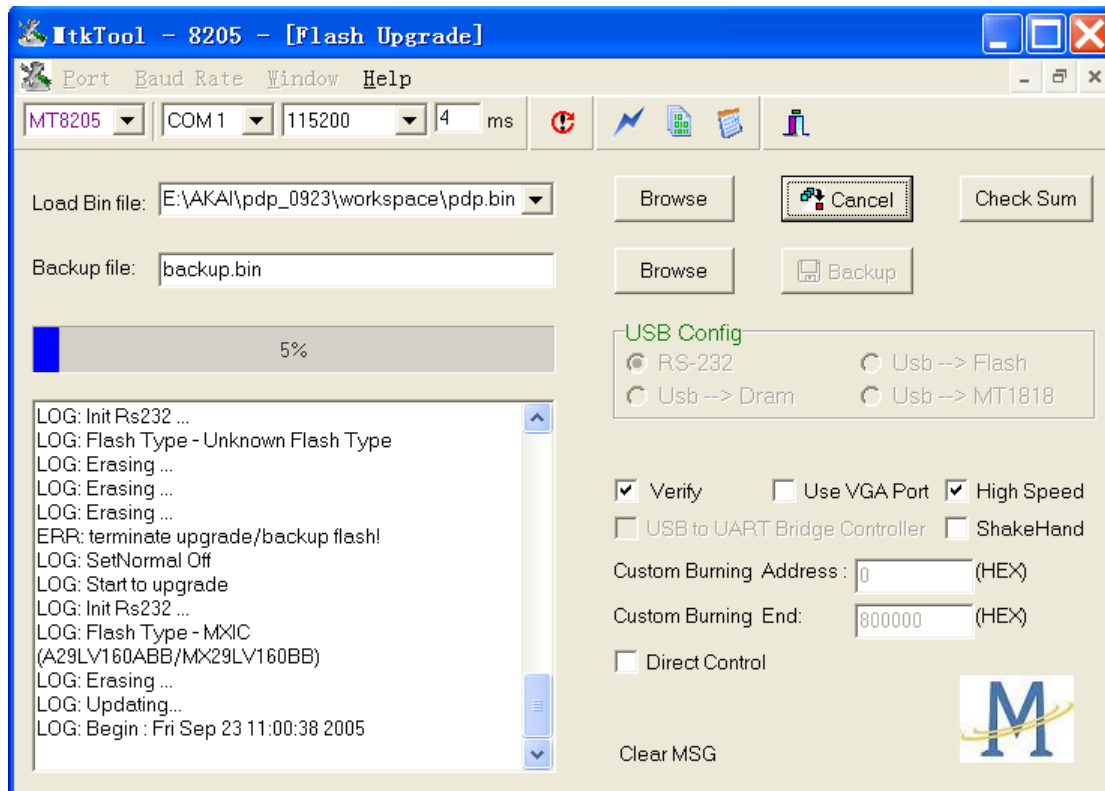
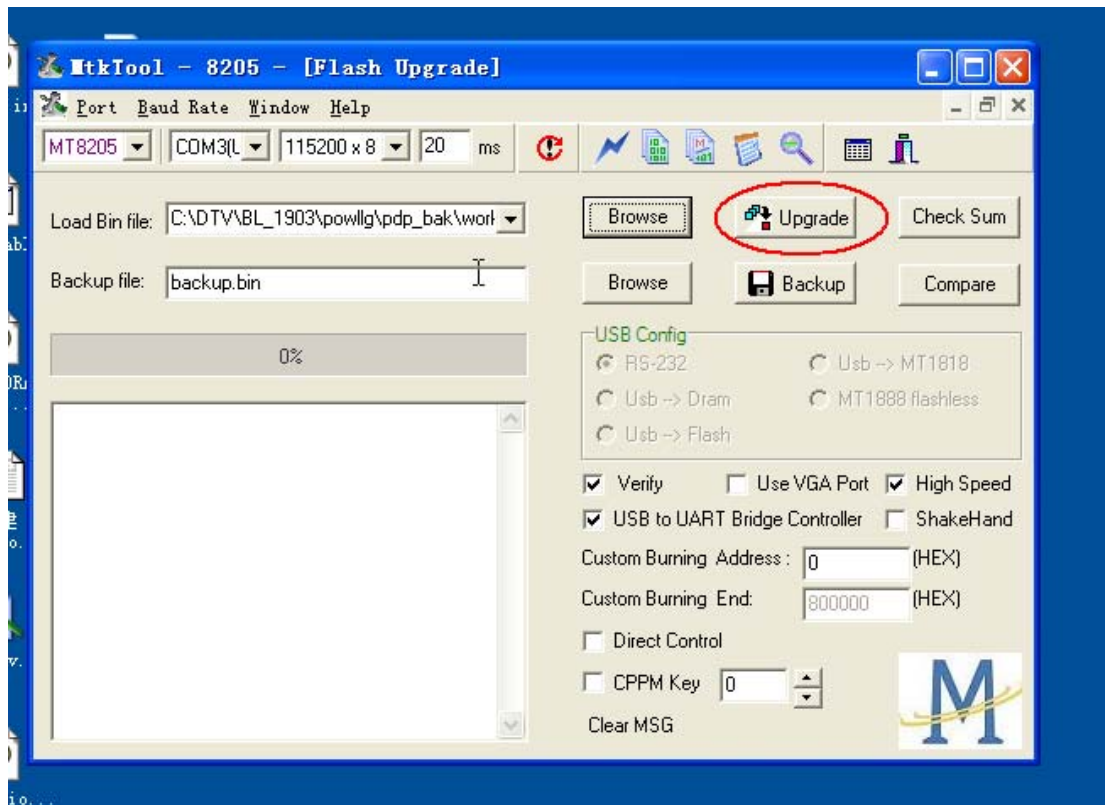

- 9) The update process is successful as the progress bar is 100%. After the update process is ok, turn off power and wait indicator light is off. Turn on power and TV can work.

Checking

It is needed to check the version of the firmware for MT8205AE which has been download into the Plasma TV .

Press Menu button of the remote control for a little long time and the OSD menu for Factory Setting is appeared on the screen .

Use the remote control and select the mode of the Factory Setting then enter the mode of the Factory Setting .

Use the remote control and select the mode of Firmware Version and then enter the mode of Firmware Version . It is easy to be found the version of the current firmware for MT8205AE is as the following : “Firmware Version : VXX ”

Process of update MT5351AG

Preparing :

- 1) Connect RS232-VGA download line, One connector is connected to VGA connect port of Plasma TV while another side is connected to PC COM port.
- 2) Store the MtkTool into the PC

Downloading :

- 3) Turn on AC power switch of the Plasma TV and then press the button “standby” of the remote control . The image could be found on the screen of the Plasma TV while the color of the power indicator is green . (the mode of the Plasma TV will be standby mode if after turn on the main power switch only .)
- 4) Execute MTKtool and select the chipset as MT5351AG. (the software of MTKtool will be sent to your side)

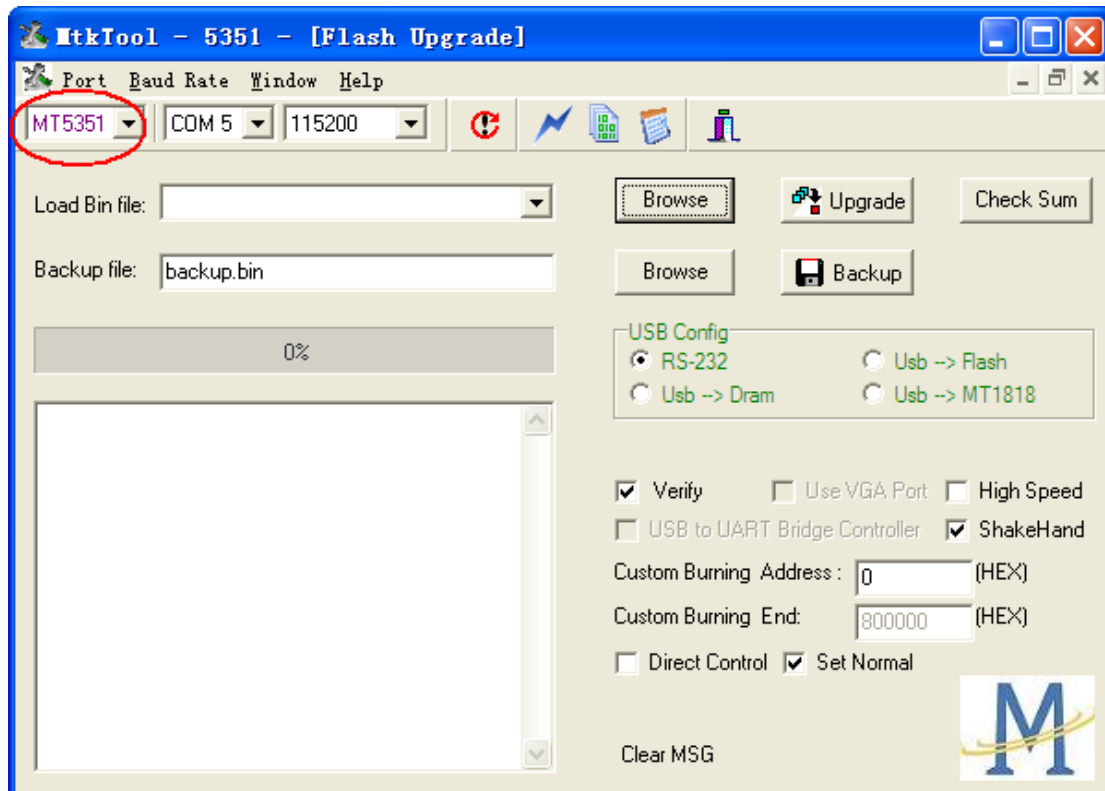

5) Select current COM port. (please try to check the COM port of your PC).

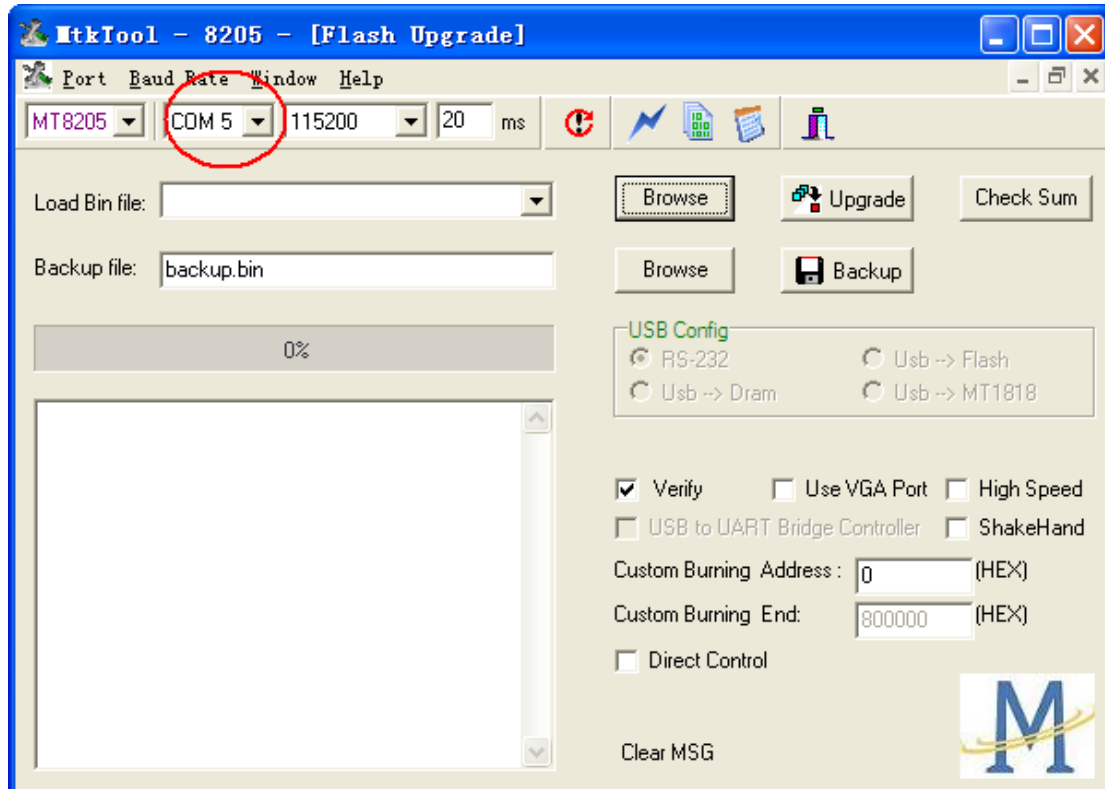

6) Choose the bit rate as 115200.

7) Select the update binary by pressing browse button. For example, the binary file name is

XXXX_PDP4210EA_ATSC_IT_000000XX_X_P.bin. (this update firmware will be sent to your side)

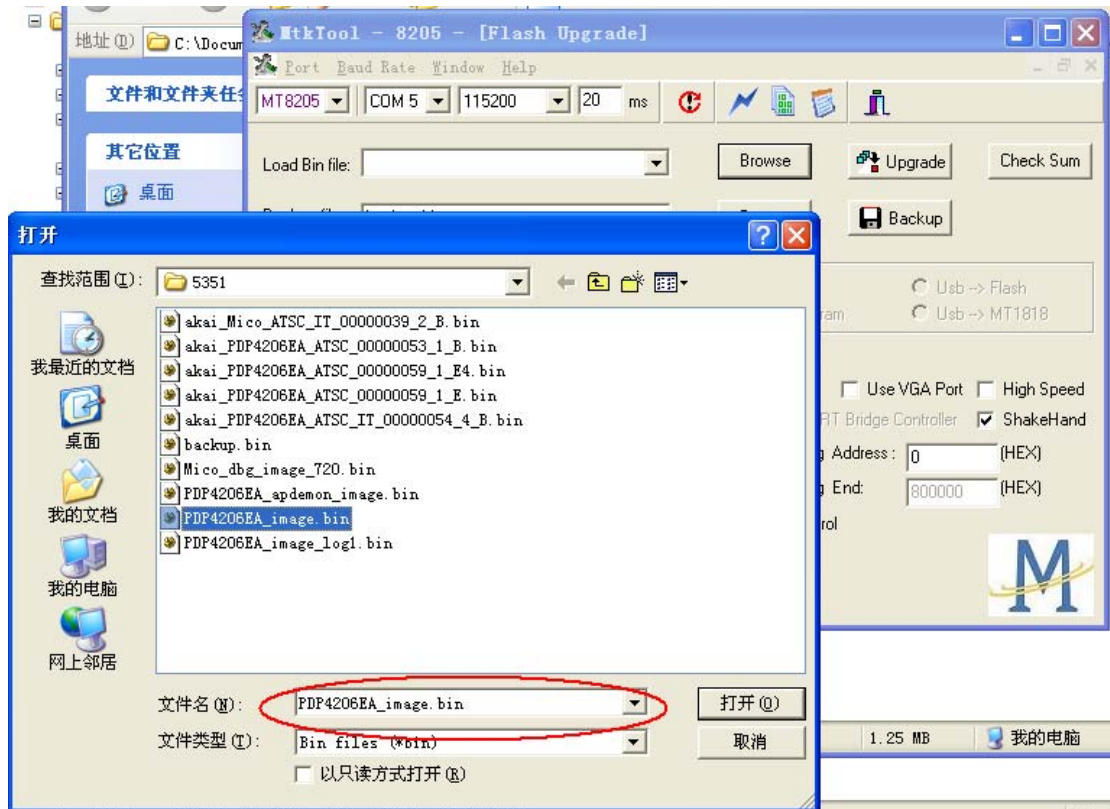

8) Press Upgrade button and start update process.

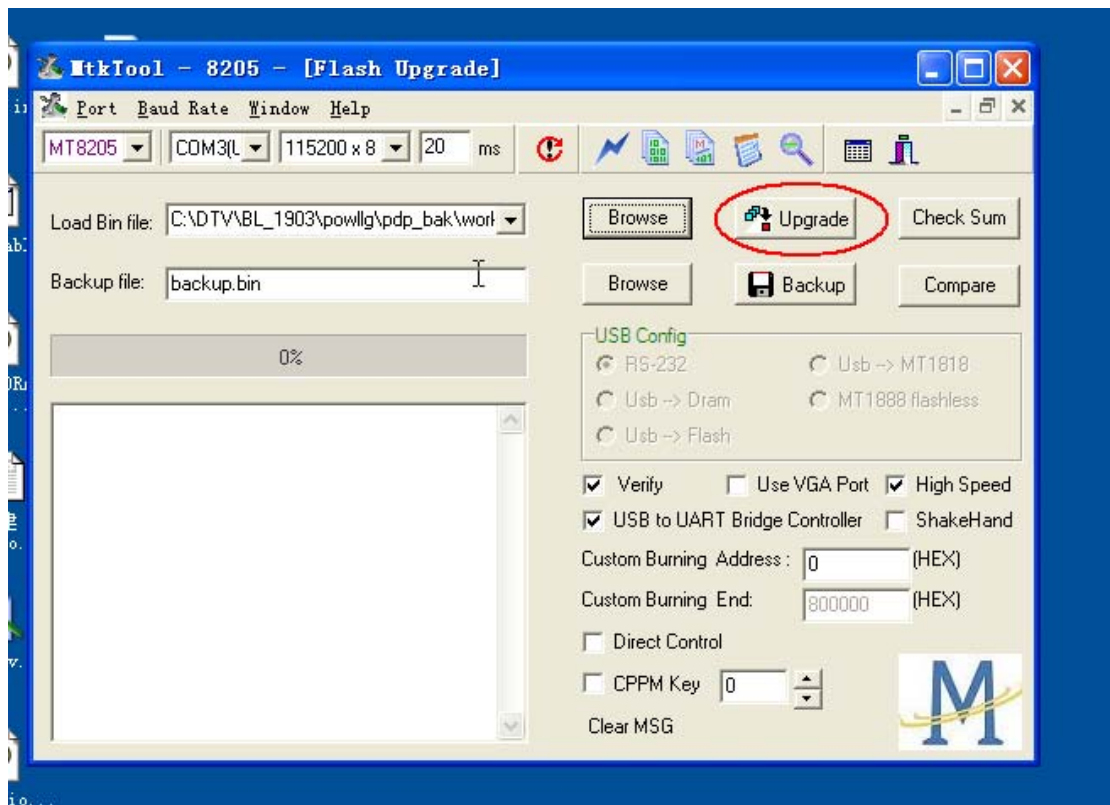

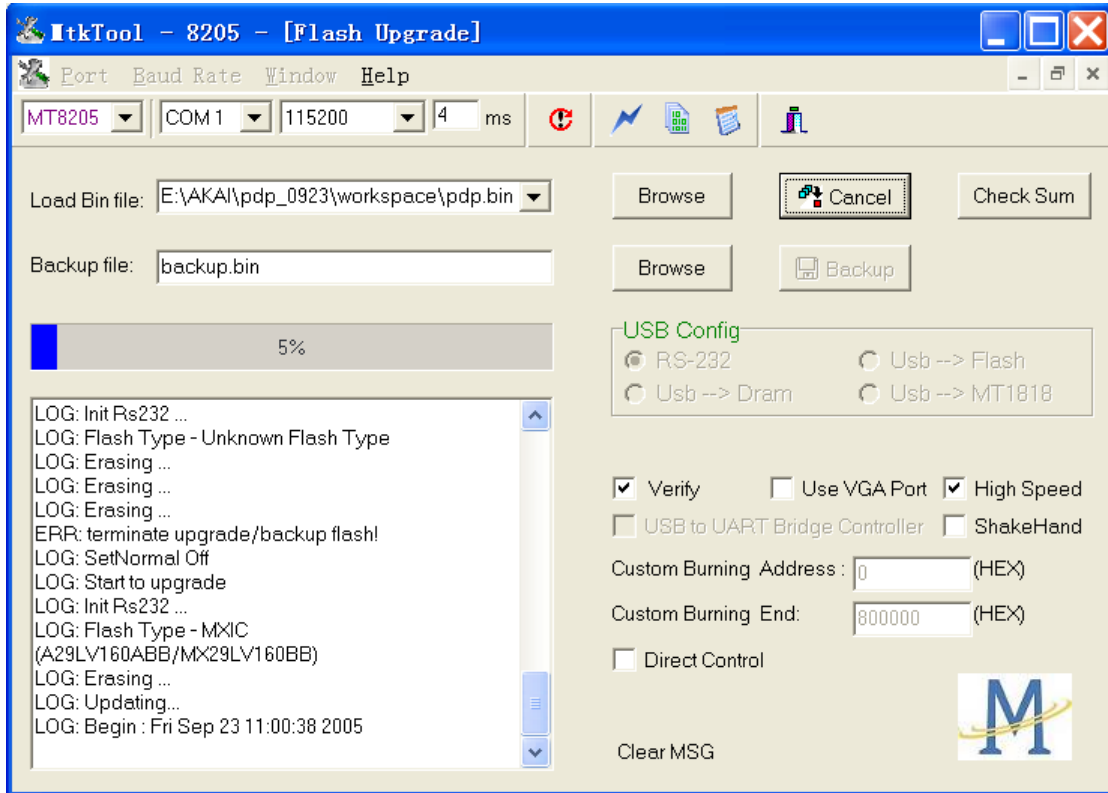

9) The update process is successful as the progress bar is 100%. After the update process is ok, turn off power and wait indicator light is off. Turn on power and TV can work.

Checking :

It is needed to check the version of the firmware for MT5351AG which has been download into the Plasma TV .

Press Menu button of the remote control and the main OSD menu is appeared on the screen .

Use the remote control and select the mode of the adjustment .

Use the remote control and select the mode of DTV

Entry the mode of DTV

Input “0000” (zero , zero , zero , zero) of the remote control while the Plasma TV is under the above condition . Then enter the mode of factory after input the digits .

It is easy to be found the version of the current firmware for MT5351AG is “XXXX_PDP4210EA_ATSC_IT_000000XX_X_P”under the mode of factory .

